

CARGO FLOOR®

Additional assembly instructions

**Protected Seal
156,8 mm [6.17"]**

INTRODUCTION

The assembly instructions outlined in this book will enable you to assemble the Cargo Floor system you have purchased correctly. Every effort has been made, by means of diagrams and text, to ensure a clear and simple installation. To ensure the durability and reliability of this revolutionary loading and unloading system, it is important that you follow the assembly instructions as outlined in this book completely, and use quality materials in accordance with the specifications. Please note that the guarantee is only valid if the Cargo Floor system has been assembled in accordance with these assembly instructions. The latest available version can always be found on our internet site: Cargofloor.com

The measurements given in this instruction start with the metric system after which between brackets [0] the imperial measurement is mentioned.

 **If the indications in this manual, as well as those stated in the user manual, are not followed this could result in damages and/or injuries.**

 **If your customer had any specific wishes we advise you to contact Cargo Floor B.V. This especially when what is wished for differs from the so-called normal use.**

TABLE OF CONTENTS

Introduction	2
(Additional) instructions	2
Important recommendations and guidelines.....	3
Emergency stop.....	5
General instructions.....	6
Cutting the floor profiles to size	7
Determine the position of the holes in the profiles.....	8
Drilling the holes in the floor profiles.....	9
Mounting the endcaps	10
Mounting the plastic side profile	11
Mounting the seal	12
Fastening the seal	13
Securing the floor profiles to the drive unit	15
Fastening of the non-moving side profiles.....	15
Sealing the front side of the floor	16
Contact data	17

(ADDITIONAL) INSTRUCTIONS

The following (additional) instructions are available:

- Assembly CF3 LP-2 15-160
- Assembly CF100 SLL
- Assembly CF500 SLC
- Assembly CF500 SLC Power Speed system
- Assembly CF500 SLC Leak Resist Centre drive
- Assembly CF500 SLC 15/156,8 [6.17"] XHDI / HD
- Assembly CF600 HDC
- Assembly CF800
- Assembly Protected Seal 156,8 mm [6.17"]
- Assembly Semi Leak Proof (SLP) system

The latest available version can always be found in the downloads section on our internet site: www.cargofloor.com/en/downloads

IMPORTANT RECOMMENDATIONS AND GUIDELINES

Before putting the Cargo Floor loading and unloading system into operation, follow the recommendations provided below and check the specified checkpoints to avoid damage to the Cargo Floor system and the vehicle.

Please review the important instructions before operating the Cargo Floor system and loading cargo into the vehicle. Likewise, before loading cargo, check the operation of the various control switches/valves to familiarise yourself with how the system works. We strongly recommend that you perform these checks when picking up the vehicle from the dealer so that your skilled supplier can answer your questions and provide you with any necessary advice or guidance you may require.

Important:

- Always check that the selected loading or unloading direction is actually activated and occurring!!
- If the system fails to start, turn off the Cargo Floor system and the hydraulic pump and follow the recommendations and guidelines provided below. Do not repeatedly try to start the system as this may result in damage to your Cargo Floor system and/or vehicle.
- After use, turn off the Cargo Floor system and hydraulic pump. Set switches to the "0" position and the lever in neutral.

In case of doubt or uncertainty about these recommendations and guidelines, always contact your dealer or an official workshop.

The Cargo Floor system comes standard with an operating manual, but if this has not been supplied, please contact your dealer or download it from the official Cargo Floor website: [Cargofloor.com, download.](https://www.cargofloor.com/download)

- A) Always open the vehicle's doors before turning on the hydraulic pump. Note! Build-up of pressure against the doors can open them with force. Also some of the cargo can fall out of the vehicle by itself after opening the doors, therefore KEEP CLEAR AT ALL TIMES, product could fall on top of you! Both could result in damages and/or injuries! It is always advisable to use the pneumatic door lock, if provided.
- B) 1. Check that the vehicle's (quick-detachable) couplings are properly connected to the P (Pressure line) and the T (tank/return line). Also check that the couplings are fully tightened or slid completely into each other.
IMPORTANT: the pressure and return line connectors may not be reversed or exchanged to prevent dirt or water from entering the lines when connecting them!
2. Before connecting, check that the non-return valves can open easily (check: the non-return valves should open easily when pressed with the finger, if not, potential pressure build-up in the hydraulic lines may be preventing the system from starting).
NOTE: Incorrectly connected or unopened hydraulic couplings will cause serious damage to the Cargo Floor system and the vehicle.
- C) The vehicle (pump) must be fitted with a pressure relief valve that is set at the maximum pressure according to the system, see the technical specs. If fitted, check that the dual-function lever (function: tipper/Cargo Floor) is in the Cargo Floor position. Pressure may not exceed the maximum adjusted and allowable operating pressure of the Cargo Floor system. An incorrectly adjusted pressure relief valve can cause damage to the Cargo Floor system and the vehicle.
- D) During operation, the (hand)brake of the vehicle must always be applied. You must, however, move the vehicle forward on time to unload it quickly in order to prevent unnecessary strain and wear to the floor and the vehicle.
- E) Use of a wireless remote control is permitted only if it is fully tested before the start of each loading or unloading operation. Always check if the function you have selected is actually activated and taking place. If, for example, you have accidentally pressed the load function when you actually meant to press the unload function, irreversible damage may occur to the Cargo Floor system and the vehicle.
- F) During operation of the Cargo Floor system, all existing STOP and control knobs/levers must be freely accessible.

- G) The pressure filter element needs to be replaced at least once a year. If the couplings between the vehicle and the Cargo Floor system are regularly removed, it is advisable to check the pressure filter for dirt build-up and replace the pressure filter element more often, if necessary. If provided, also check the return filter (not supplied with the Cargo Floor). Failure to replace a filter element on time may cause damage to or malfunctions in the Cargo Floor system and the vehicle.
- H) Moving parts must be shielded. Always maintain at least 10 meter [30'] distance from the Cargo Floor system when it is in operation.
- I) In the event of malfunctions/maintenance work, you may approach the Cargo Floor system only if all equipment, including the hydraulic pump, have been shut off, and the Cargo Floor system and the electro-hydraulic aggregate have been disconnected from the power supply and pump.
- J) Regularly check and, if necessary, tighten any loose bolts that secure the aluminium floor profiles to the Cargo Floor system. All such checks can simply be performed inside the vehicle itself by qualified personnel. The Cargo Floor system must, however, be turned on in unloaded condition and the person performing the check must place his finger half on the floor profile and half on the bolt. There should be no appreciable movement/space between the floor profile and bolt. Failure to check these bolts may lead to damage to the Cargo Floor system. During this check, a second person must also be present to switch off the Cargo Floor system.
- K) Check that the minimum required amount of oil is present 150 liter [40 US gallon]. Too little oil in the hydraulic tank will cause damage to both the pump and the Cargo Floor system.
- L) Do not allow the number of strokes to exceed the maximum allowable 16 power strokes per minute. Only a CF500 SLC Power Speed Cargo Floor system may deliver up to 23 beats per minute. A higher number of power strokes can cause damage to the Cargo Floor system and the vehicle.
- M) Hydraulic lines, couplings and hoses with very small diameters will cause damage.
- N) If the Cargo Floor system fails to start or operates incorrectly, the Cargo Floor system and the hydraulic pump must be shut down immediately. Subsequently, check all the checkpoints before switching the pump and the Cargo Floor system back on. To prevent the oil from overheating, regularly check the oil temperature by CAREFULLY and CAUTIOUSLY touching the line and or oil tank. If either is too hot to the touch, stop touching them right away. **WARNING: TOUCHING OVERHEATED OIL AND COMPONENTS CAN CAUSE BURNS!**
- O) The cause of failure or malfunctioning of the Cargo Floor system may also be due to other hydraulic components that may or may not be connected to the same hydraulic circuit of the Cargo Floor system.
- P) Jamming of the floor profiles caused by the transport of abnormal loads and or the freezing of the floor or of the product to the floor may result in damage to the Cargo Floor system and the vehicle. Recommendation: in the event of freezing, stop the system and try to find a hall (heated area) to allow the product to thaw.
- Q) Because the electrical power supply of the Cargo Floor system is often connected to the lighting circuit of the vehicle, it is advisable to turn on the lighting throughout the operation of the system.
- R) Maintenance and repairs to the Cargo Floor system may be only performed by qualified personnel. Use only original Cargo Floor components to ensure maximum reliability and long service life.
- S) Maximum cargo weight is subject to the limits set by law and applicable regulations. Even if the system can transport heavier loads, the law determines the maximum limit. Excessively heavy cargo can cause damage to the Cargo Floor system and the vehicle.
- T) Check that the correct type and quality of hydraulic oil is used. The use of incorrect oil type may cause damage to the Cargo Floor system and the pump.
- U) Check the vehicle for correct voltage. Make sure there are no open electrical connections. A faulty electrical system can cause damage to the Cargo Floor system and the vehicle.
- V) Check that the bulkhead, if present, is functioning smoothly and properly. A properly functioning bulkhead ensures that the product is unloaded in a clean and quick fashion. A malfunctioning bulkhead may extend the unloading time and cause damage to the vehicle.
- W) Use of the Cargo Floor system by unqualified personnel can cause damage to the Cargo Floor system and the vehicle.
- X) Excessively high oil temperatures will cause damage to the Cargo Floor system and other hydraulic components, such as the pump.

- Y) It is at all times advisable to stop the Cargo Floor system when all the piston rods are retracted. This is usually the case when the floor profiles are positioned towards the unloading end (vehicle doors). Unretracted piston rods may cause damage to the Cargo Floor system.
- Z) To prevent damage to the floor profiles, exercise caution and limit the dump height as much as possible. The transport of unauthorised goods, such as aggressive, corrosive, hot, hard, sharp and viscous materials may cause damage to the Cargo Floor system and the vehicle. Avoid loading and unloading sharp objects. Loads that are softer than the hardness of the floor profiles will extend the service life of your system; if in doubt, use a protective cloth or consult your dealer.
- AA) Forklift trafficable. In principle, the floors are completely trafficable and can be driven over by forklifts, but always consult your dealer for advice on the maximum loads allowed on your vehicle. Overloading will cause damage to the Cargo Floor system and the vehicle.
- BB) Always return emergency control(s) to their original non-activated position after use.
- CC) During the operation of the system, test the temperature of the oil by touching the side of the tank. If the oil is so hot that you cannot continue to touch the tank, switch off the pump to allow the oil to cool off and determine what is causing the overheating. Stop loading or unloading if the oil is too hot, as this will irreversibly cause damage to the Cargo Floor system and the other hydraulic components.
WARNING: TOUCHING OVERHEATED OIL AND COMPONENTS CAN CAUSE BURNS AND INJURIES!
Option: your Cargo Floor system could be equipped with an oil temperature safety switch which will switch off the system automatically when it starts to overheat.
- DD) During loading and unloading operations, the load should be spread to give an even weight distribution over the floor area, otherwise the load may stall. Tip: when transporting pallets, place softwood boards of 300 x 18 x 2350 mm. [12" x 0.75" x 92.5"] to distribute the pressure more evenly.
- EE) The constant pressing of the load against the head board or the doors can lead to extra wear of the complete system. Also the construction can be damaged. Please consult your supplier about the optimizing possibilities or in order to prevent problems occurring.
- FF) The user/operator/driver that is operating the Cargo Floor system is compelled to remain a safe distance from the Cargo Floor system at all times, from the time of switching on the hydraulic pump until turning it off. He should ensure that no dangerous situations can occur. When the process malfunctions or if other people are present he should shut down the Cargo Floor system, or hydraulic pump, immediately.
- GG) No unauthorized alterations/modifications/changes/adjustments may be made to any part of the Cargo Floor drive unit and system.

WARRANTY

Warranty is subject to prior approval by Cargo Floor B.V.! To request warranty coverage, visit Cargofloor.com to fill out and submit the warranty application form provided there; do not forget to include your Cargo Floor system number on the form.

EMERGENCY STOP

In the event of an EMERGENCY, operation of the Cargo Floor system can be halted as follows:

- By pressing the red stop button on one of the control switches;
- By turning all switches to position "0";
- By putting the handle of the control valve in the middle "0" position (only B and A control);
- Turning off the PTO pump/engine;
- Turning off the main switch of the power supply;
- Turning off the motor of the electro-hydraulic aggregate.

GENERAL INSTRUCTIONS

When assembling a Protected Seal floor a number of steps are very different from the assembly of a standard aluminium floor. For all the other assembly instructions, we refer to the assembly instructions of the CF500 SLC 156,8 [6.17"] Bulkmove.

The Protected Seal profile consist of various components:

- Alu 7/156,8mm Protected Seal (parts no. [682.5841](#))
- Aluminium endcap for profile 156,8 mm. [6.17"] (parts no. [5164010.1](#))
- 5x plastic side profile (protected seal) (parts no. 4104011)
- Rivet 4.0x6.0 mm. (parts no. [5017012](#))
- Low Friction Seal (between the floor profiles) (parts no. 4008016)
- Rivet for seal installation 3,2x14 (parts no. [5017001.1](#))

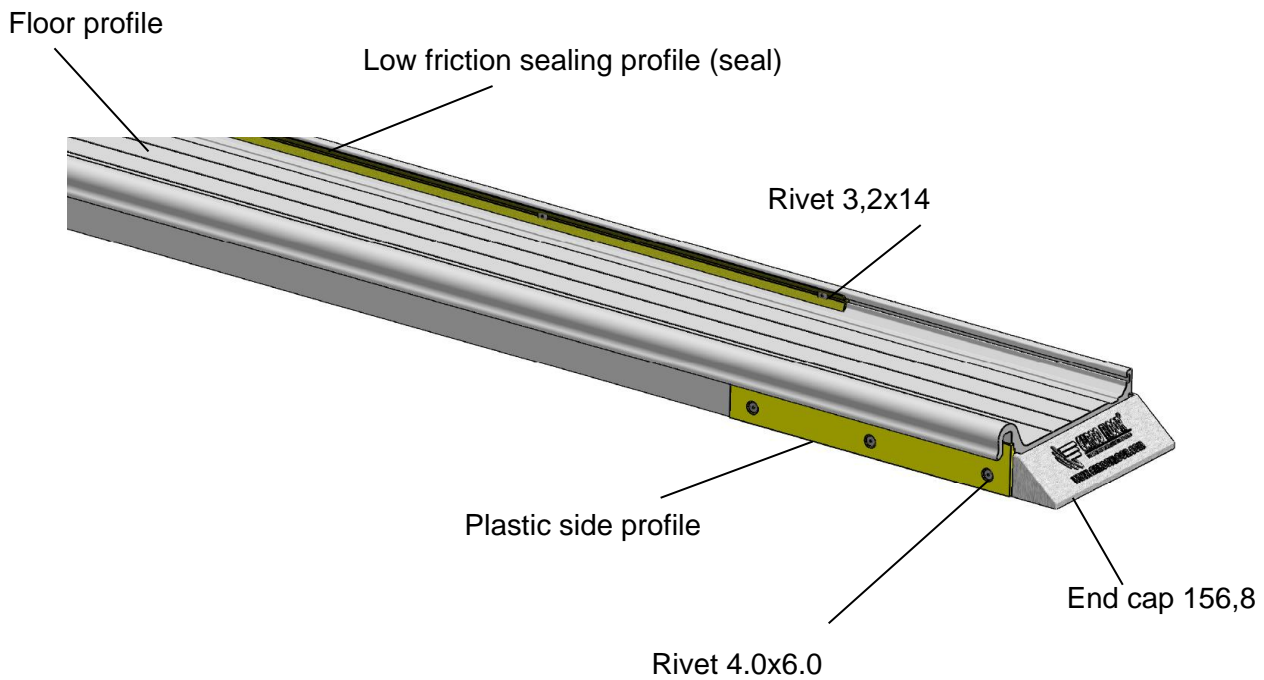

In the instructions below we will – in a number of steps – point out the differences, adjustments that have to be made and points that need attention.

CUTTING THE FLOOR PROFILES TO SIZE

After the plastic bearings have been mounted, the aluminium floor profiles can be cut to size, see fig. 16.

Attention: the floor profiles need to be shorter than the inner length of the construction. Check if the door falls inside or outside the rear portal.

At the rear the length of the endcap 40 mm. [1.6"] needs to be taken into account.

On the front and the rear of the construction, a space of 20 mm. [0.8"] per side needs to be adhered.

FIG. 16

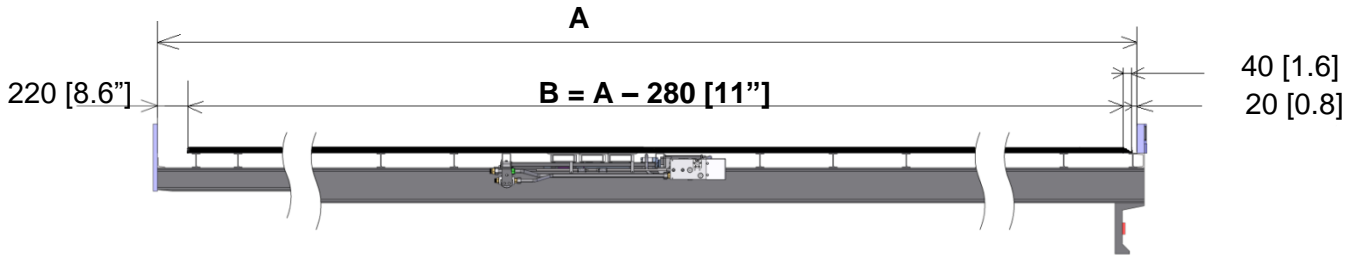

After cutting the floor profiles to length they need to be rounded-off (bevelled) at the front, so as to ensure a smooth guiding of the floor profile while sliding in, and to prevent damage to the plastic bearing. To make mounting easy the rounded-off sides need to be placed in the mounting direction of the vehicle.

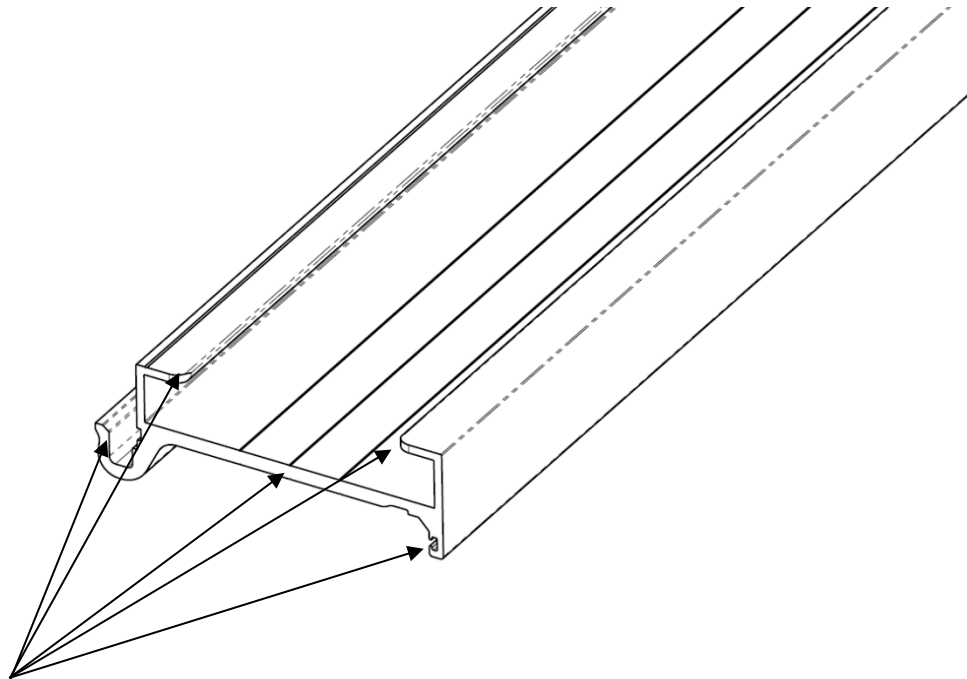

Bevel front sides on both sides

DETERMINE THE POSITION OF THE HOLES IN THE PROFILES

First, you need to determine the position of the holes in the profiles, see fig. 19.

Check if the cylinders are fully retracted. You check this as follows: the ends of the piston rods may not protrude out of the guide block for cylinder bar more than 5-10 mm. [0.20-0.39”].

The position of the first hole is determined by taking the measurement from the inside of the door side to the first hole in the U-profile moving cross member of the third group. From this measurement you deduct 60 mm [2.4”] and with this you have determined measurement A.

Put a mark on the bottom side of the 5 profiles of the 3rd group at the spot of this first hole.

The 5 profiles of group 3 will have the hole pattern on measurement A.

The 5 profiles of group 2 will have the hole pattern on measurement A + 195 mm [7.7”].

The 5 profiles of group 1 will have the hole pattern on measurement A + 390 mm [15.4”].

FIG. 19

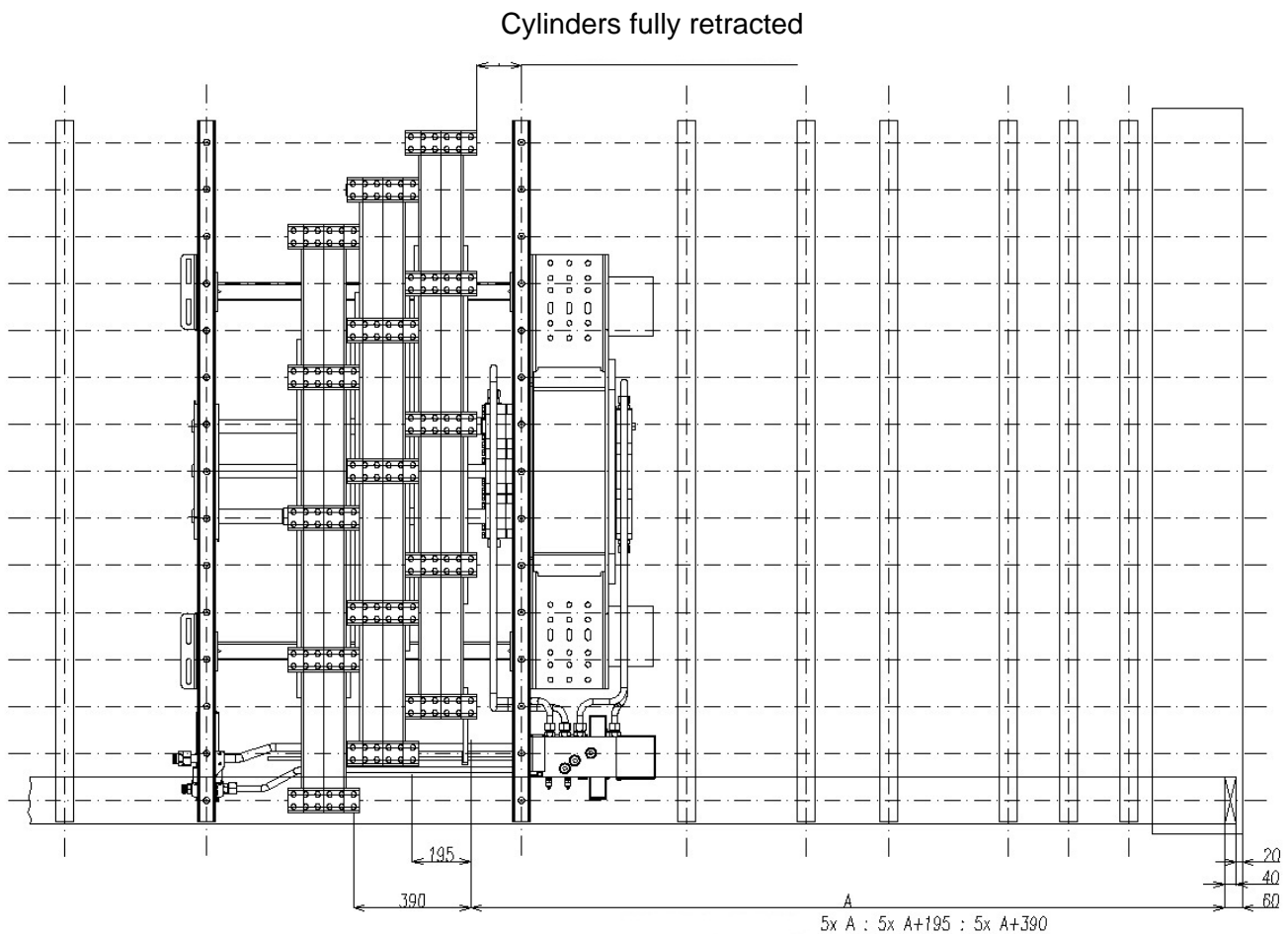

DRILLING THE HOLES IN THE FLOOR PROFILES

The 8/12 holes in the profiles need to be drilled before these are placed.

Using the 8xM12 screws

If the system is a standard CF500 SLC 15/156,8 version you use 8 screws per U-profile. The 4 holes on the sides are then used.

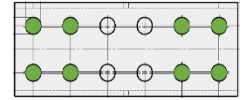

Using the 12xM12 screws

If the system is a Power Speed or is used in a stationary application 12 screws need to be used.

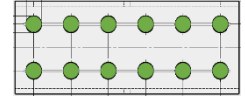

- Place all of the floor profiles with the sealing grooves in the same direction before you start drilling.
- Then drill according to figure 19 the necessary number of floor profiles per moving cross members using the Cargo Floor drill jig, part no. 9111011.
- Pre-drill 8/12 holes of $\varnothing 4.5$ mm [$\varnothing 0.18$ "] with the aid of the drill jig on the inside of the floor profile . Then drill out the holes, from the same direction, to $\varnothing 12.5$ mm [$\varnothing 0.5$ "]. (fig. 21 A)
- Next the holes need to be countersunk from the top side using a good countersink bit according to the specification G136 HSS DIN 335 C, code 13628.0 (figure 21 B) Make sure that the hole is countersunk to the right depth; the screw head must not stick out above or under the floor profile. See figure 21 C.

FIG. 20

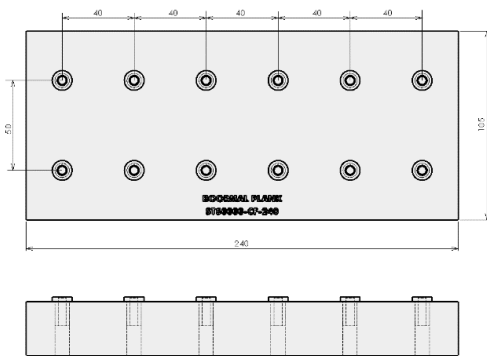

FIG. 21 A

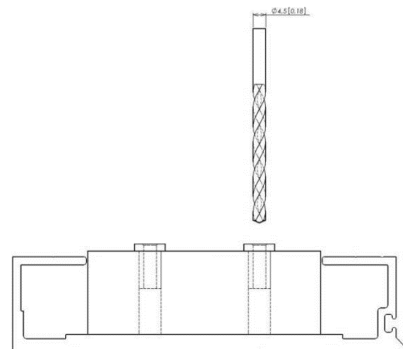

FIG. 21 B

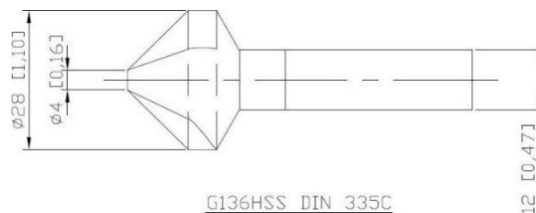

FIG. 21 C

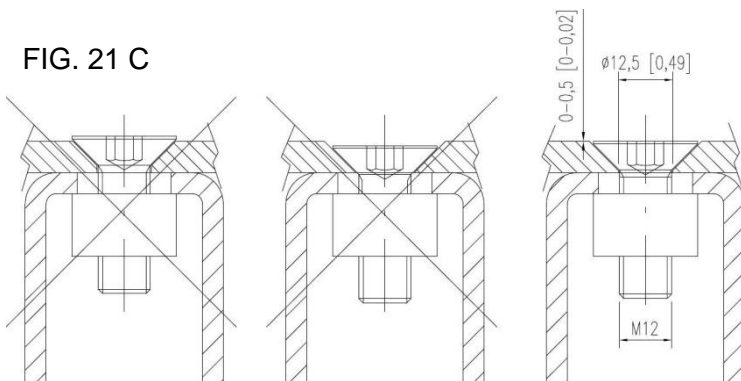
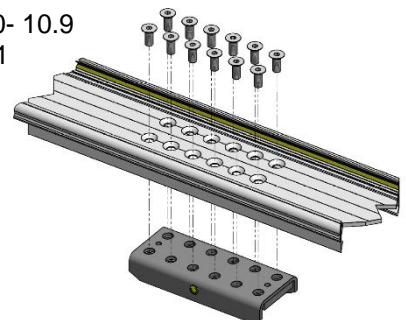

FIG. 21 D

M12 x 30- 10.9
DIN 7991



MOUNTING THE ENDCAPS

The endcaps can now be mounted. The endcap can be hammered into the profile with a plastic hammer, then weld the endcap.

Weld the end cap to the outer top side.

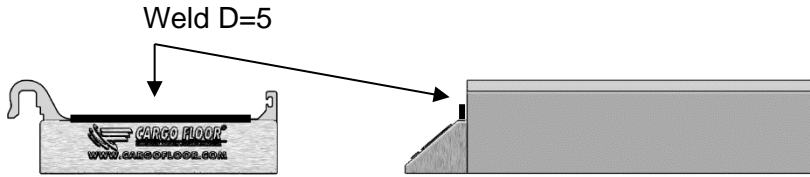

Aluminium endcap for profile 156,8 mm. [6,17"], part no. 5164010.1

MOUNTING THE PLASTIC SIDE PROFILE

5 plastic side profiles (parts no. 4104011) need to be mounted to every profile and the side profile, on the following spots:

- At the end of the profile, end cap side
- At the front side of the profile
- Near moving crossmember no. 2
- 2 evenly distributed along the length of the profile

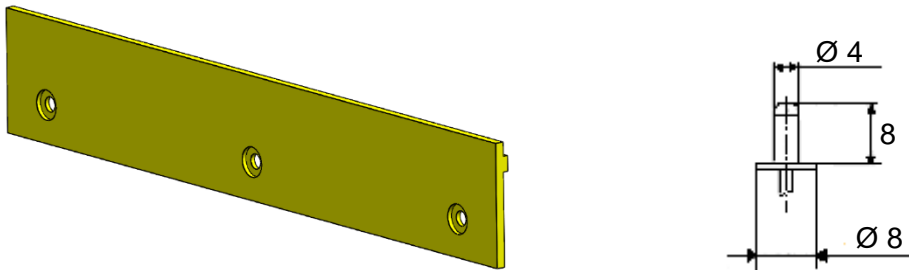

The side profile needs to be mounted with 3 rivets, 4.0x6.0 mm (parts no. [5017012](#)). The head of the rivet may not protrude out of the plastic side profile. Place the plastic profile on the mounting spot, so that it is placed fully flat against the profile and the stand-up edge of the of the plastic profile is in the gutter of the profile. Copy the hole pattern of the plastic profile onto the profile and drill with drill 4 mm. through the profile and fasten the side profile with rivets 4.0x6.0 mm.

Evenly distributed along the length and near moving cross member no. 2

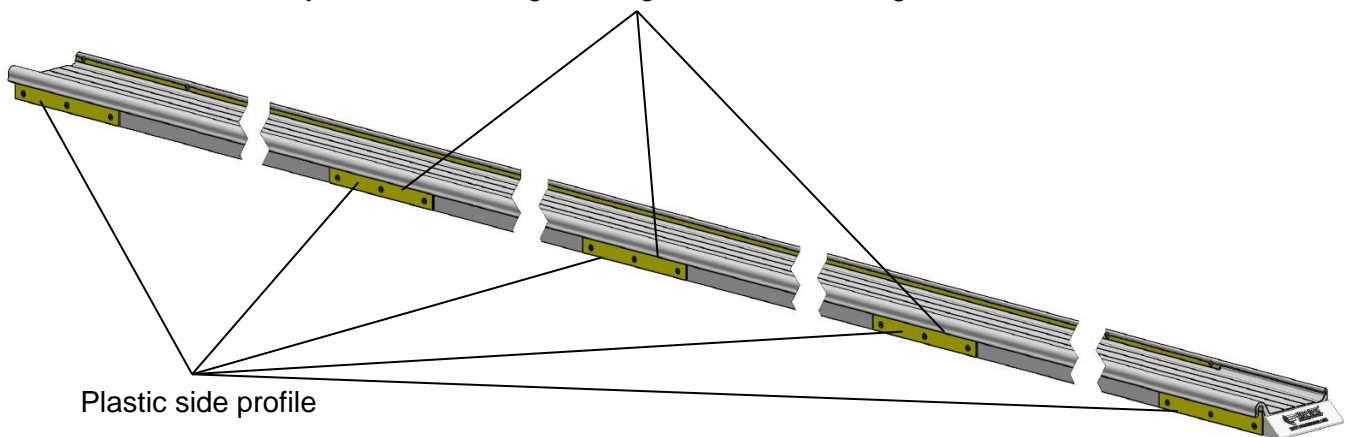

MOUNTING THE SEAL

Place all of the floor profiles on their sides against one another, with the groove facing upwards. The groove in the floor profile needs to be clean (if necessary blown through with compressed air) before the seal can be mounted.

The seal is supplied on a roll. In order to install it easily, one needs to determine from which side of the groove the seal needs to be pulled.

The seal lip of the seal always needs to point downward (this differs from the standard mounting) and the seal lip needs to point upwards (see fig. 22 A).

FIG 22 A

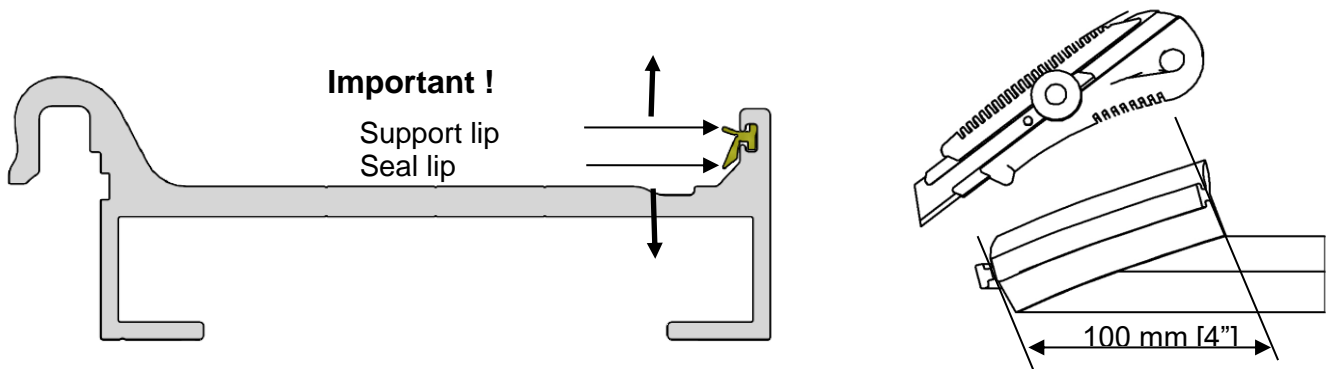

To aid the mounting of the seal, snip / cut about a little into the T-form at about 100 mm. [4"] from the start (this will form a handgrip), see figure 22 A.

Next, place the T section of the seal in the groove and, using the handgrip, pull the seal into the groove in the floor profile until the end of the floor profile. The cut will now be at the end of the floor profile.

FASTENING THE SEAL

⚠ Attention!!
No seal will be installed on the first 250 mm. [9.8"] at the end of the endcap side of the floor profile.

The low friction seal needs to be fastened with rivet 3.2x14 mm.

Start with the fastening on the side of the endcap. (If the handgrip is at this side, cut it off.) Now pull the seal back till 250 mm. [9.8"] from the end of the aluminium profile.

Drill a hole of 3.2 mm. [0.13"] (max 3.5 mm. [0.14"]) at 20 mm. [0.8"] distance of the end of the seal (meaning 270 mm. [10.6"] from the end of the aluminium profile) through the seal, gutter and the aluminium profile.

Because the rivet may no protrude out of the floor profile at the other side, a countersunk hole needs to be drilled on the other side in which the rivet can settle.

⚠ Attention!!
The rivet for the low friction seal may not protruded out of the profile.

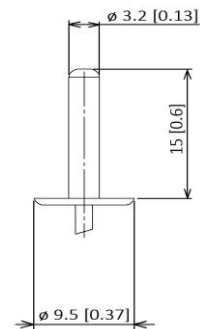
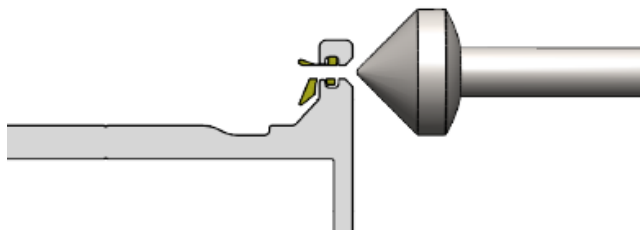

Part no: [5017001.1](#)

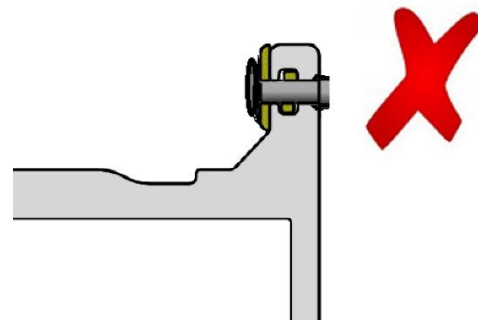
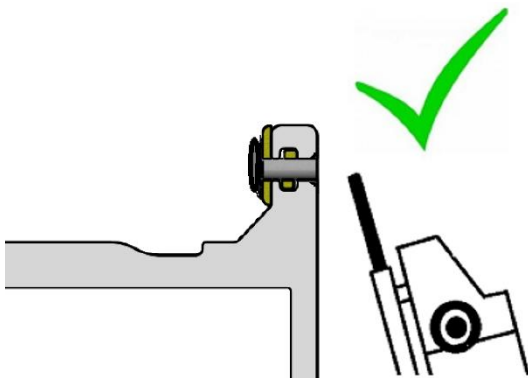

If the rivet does protrude on the profile side after mounting it needs to be grinded flat, equal the floor profile.

Then tension the low friction seal by stretching it for at least 600 to 1000 mm [23.6" to 39.37"] (until you start to feel higher resistance and the length of the vehicle), this means about 10 to 15 kg [22 / 33 lbs] pulling force. Place the last rivet at 20 mm [0.8"] from the end of the profile. After tensioning the seal place the remaining pop-rivets according to figure 22 B.

FIG. 22B

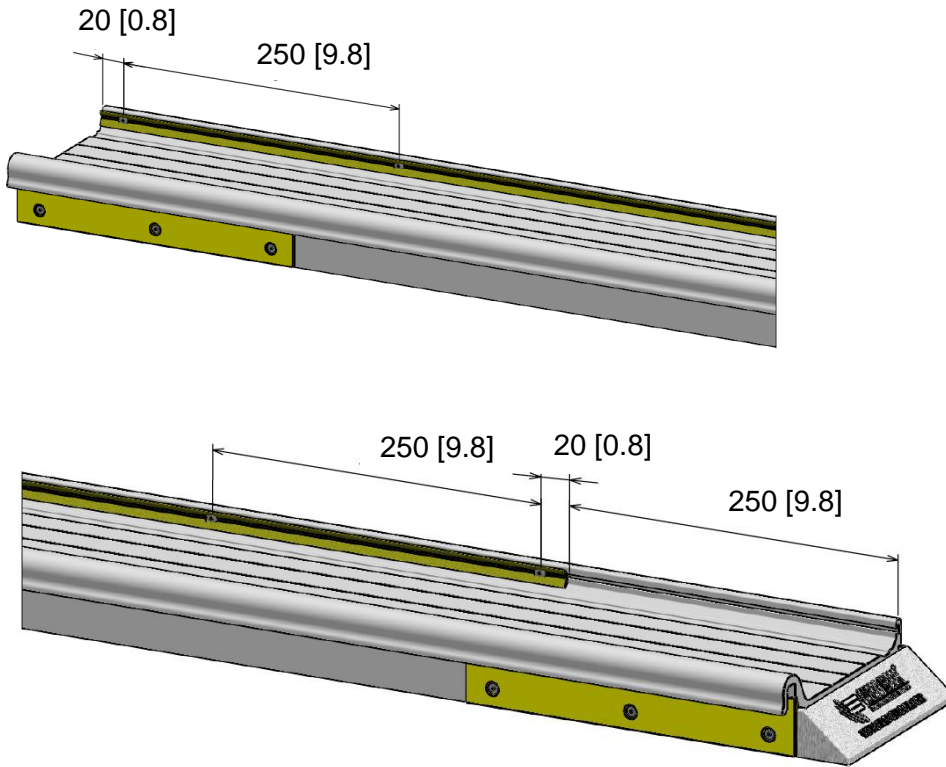

SECURING THE FLOOR PROFILES TO THE DRIVE UNIT

After the floor profiles have been cut to size, rounded-off, drilled, and had the seals and endcaps mounted, they can be slid over the plastic bearing at the required position (matching up the hole pattern with respect to the moving cross member). You need to carefully guide the floor profiles during the mounting procedure.

Next, mount the provided M12 bolts with countersunk head using Allen No. 8. A torque of 100 – 140 Nm [72 – 105 lbf.ft] should be used to tighten the bolts. One person can do this from above, and the bolts need to be well tightened. Every bolt should be fitted with Loctite (Loctite 243 cat.o. 23286 screw thread locker).

FASTENING OF THE NON-MOVING SIDE PROFILES

In order to make a non-moving side profile a Protected Seal profile is sawed through lengthwise at the right width.

The side profile with the gutter also needs to have the seal installed, exactly the same way as the rest of the profiles.

The side profile with the protective arch has to have the plastic side profiles mounted.

Before the non-moving profiles are fastened these need to be pushed in the direction of the sidewall.

Next, the non-moving profiles need to be fastened with so-called steel monobolts, with countersunk head, which may not protrude out of the profile (see fig. 24 A).

After this, the opening between sidewall and non-moving side profile needs to be sealed with a flexible sealant.

Alternatively, the non-moving profiles can be fastened with a bolt connection or small chain welds.

FIG. 24A

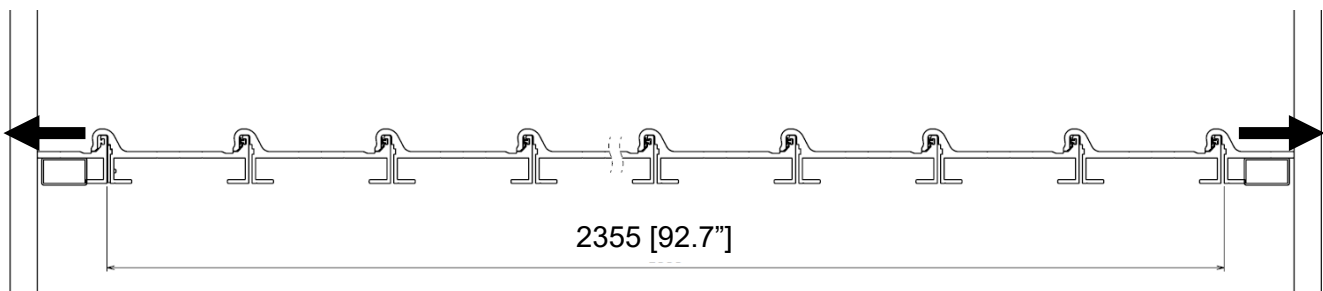

It is better not to weld the non-moving side profiles completely to the sidewall.

SEALING THE FRONT SIDE OF THE FLOOR

FIG. 25

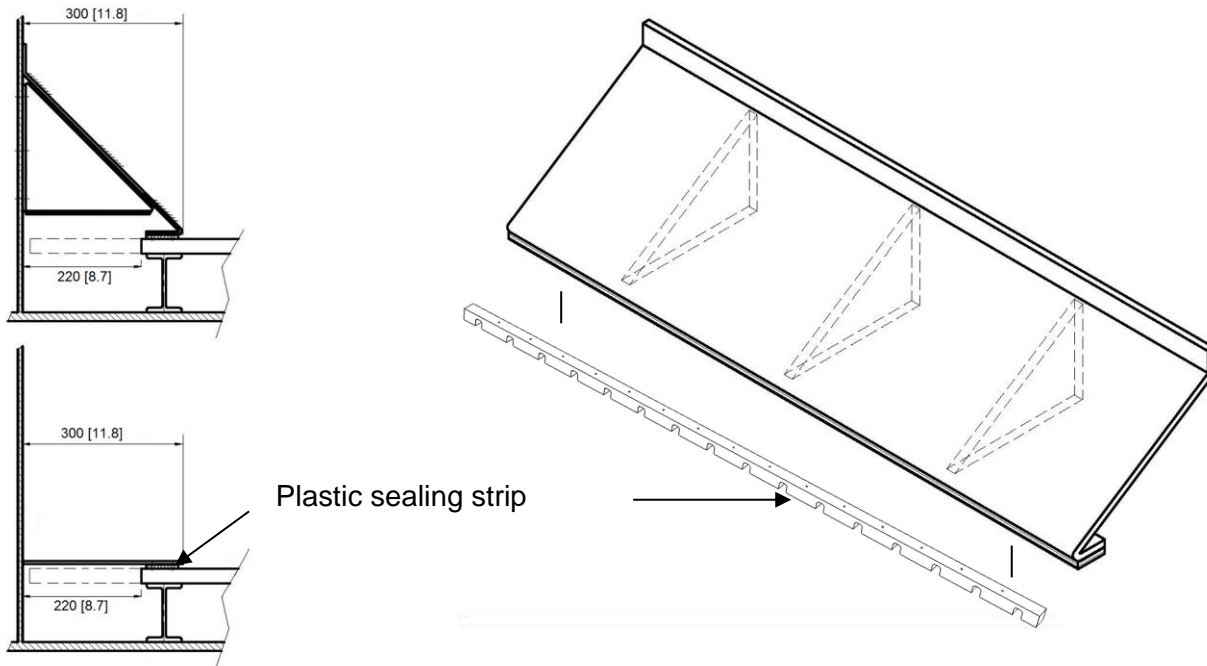

To close the opening near the head board, which is there because of the operational stroke of the system, a reinforced flat plate (width minimum 300 mm. [12"]), length depending upon the inside of the trailer, needs to be mounted on the front wall of the trailer.

At the underside of the front part of the cover plate the plastic strip Protected Seal 156,8 needs to be mounted in order to prevent wear and attain a good sealing.

Ensure here that the fasteners are mounted countersunk in the plastic strip so that they do not come in contact with the floor.

A heavily reinforced cover plate needs to be mounted at an angle of 45° for trailers that are used for loading or compressing, see figure 25.

The construction needs to be very sturdy, so that it will not buckle or rise up.

CONTACT DATA

Postal and visiting address:

Cargo Floor B.V.
Byte 14
7741 MK Coevorden
The Netherlands

Phone number : +31 524 593 900
E-mail : info@cargofloor.com
Website : Cargofloor.com
Whatsapp : +31 6 524 59 228

Order spare parts:

E-mail address : sales2@cargofloor.com
Phone number : +31 524 593 977

After Sales (technical questions and malfunctions)

E-mail address : as@cargofloor.com
Phone number : +31 524 593 944
Whatsapp : +31 6 524 59 009

Coevorden, The Netherlands

© 2024 Cargo Floor B.V.

No part of this publication may be reproduced, stored in a retrieval system, or transmitted, in any form or by any means, electronic, photocopying, recording or otherwise, without the prior permission of Cargo Floor B.V.