

# **CARGO FLOOR®**

## **Manual Intelligent Remote Control Module (IRCM)**

Cargo Floor B.V.  
is de wereldwijd toonaangevende fabrikant en leverancier van horizontaal werkende laad- en los transportsystemen.

With the help of these instructions, we want to give directions for the correct use of the Cargo Floor Intelligent Remote Control Module (IRCM) and, in case of any malfunctions, help you with the steps you can take for quick resolution of your problem.

Please read - and follow - these instructions carefully. Also read the maintenance instructions carefully, so that the Remote Control will serve you for many years without any problems.

If, after following the instructions, the Remote Control does not work, or does not work properly, please contact your supplier, who will undoubtedly help you to solve the problem.

Be sure to read the "IMPORTANT RECOMMENDATIONS AND GUIDELINES" and "IMPORTANT" sections.

### TABLE OF CONTENTS

Table of contents.....	2
Important recommendations and guidelines .....	3
Emergency stop .....	5
Intelligent Remote Control Module (IRCM) .....	6
IRCM receiver .....	7
Control the IRCM receiver without a remote control.....	8
IRCM Remote Control .....	9
Switching the IRCM Remote Control on/off.....	9
Remote Control battery .....	9
Pairing the Remote Control to the IRCM receiver .....	9
Mounting the IRCM receiver mounting bracket to the control box.....	10
Important! .....	11
Contact data.....	12

## **IMPORTANT RECOMMENDATIONS AND GUIDELINES**

Before putting the Cargo Floor loading and unloading system into operation, follow the recommendations provided below and check the specified checkpoints to avoid damage to the Cargo Floor system and the vehicle.

Please review the important instructions before operating the Cargo Floor system and loading cargo into the vehicle. Likewise, before loading cargo, check the operation of the various control switches/valves to familiarise yourself with how the system works. We strongly recommend that you perform these checks when picking up the vehicle from the dealer so that your skilled supplier can answer your questions and provide you with any necessary advice or guidance you may require.

### **Important:**

- Always check that the selected loading or unloading direction is actually activated and occurring!!
- If the system fails to start, turn off the Cargo Floor system and the hydraulic pump and follow the recommendations and guidelines provided below. Do not repeatedly try to start the system as this may result in damage to your Cargo Floor system and/or vehicle.
- After use, turn off the Cargo Floor system and hydraulic pump. Set switches to the "0" position and the lever in neutral.

In case of doubt or uncertainty about these recommendations and guidelines, always contact your dealer or an official workshop.

The Cargo Floor system comes standard with an operating manual, but if this has not been supplied, please contact your dealer or download it from the official Cargo Floor website: [www.cargofloor.com\\_download](http://www.cargofloor.com_download).

- A) Always open the vehicle's doors before turning on the hydraulic pump. Note! Build-up of pressure against the doors can open them with force. Also some of the cargo can fall out of the vehicle by itself after opening the doors, therefore KEEP CLEAR AT ALL TIMES, product could fall on top of you! Both could result in damages and/or injuries! It is always advisable to use the pneumatic door lock, if provided.
- B) 1. Check that the vehicle's (quick-detachable) couplings are properly connected to the P (Pressure line) and the T (tank/return line). Also check that the couplings are fully tightened or slid completely into each other.  
**IMPORTANT: the pressure and return line connectors may not be reversed or exchanged to prevent dirt or water from entering the lines when connecting them!**  
2. Before connecting, check that the non-return valves can open easily (check: the non-return valves should open easily when pressed with the finger, if not, potential pressure build-up in the hydraulic lines may be preventing the system from starting).  
NOTE: Incorrectly connected or unopened hydraulic couplings will cause serious damage to the Cargo Floor system and the vehicle.
- C) The vehicle (pump) must be fitted with a pressure relief valve that is set at the maximum pressure according to the system, see the technical specs. If fitted, check that the dual-function lever (function: tipper/Cargo Floor) is in the Cargo Floor position. Pressure may not exceed the maximum adjusted and allowable operating pressure of the Cargo Floor system. An incorrectly adjusted pressure relief valve can cause damage to the Cargo Floor system and the vehicle.
- D) During operation, the (hand)brake of the vehicle must always be applied. You must, however, move the vehicle forward on time to unload it quickly in order to prevent unnecessary strain and wear to the floor and the vehicle.
- E) Use of a wireless remote control is permitted only if it is fully tested before the start of each loading or unloading operation. Always check if the function you have selected is actually activated and taking place. If, for example, you have accidentally pressed the load function when you actually meant to press the unload function, irreversible damage may occur to the Cargo Floor system and the vehicle.
- F) During operation of the Cargo Floor system, all existing STOP and control knobs/levers must be freely accessible.

- G) The pressure filter element needs to be replaced at least once a year. If the couplings between the vehicle and the Cargo Floor system are regularly removed, it is advisable to check the pressure filter for dirt build-up and replace the pressure filter element more often, if necessary. If provided, also check the return filter (not supplied with the Cargo Floor). Failure to replace a filter element on time may cause damage to or malfunctions in the Cargo Floor system and the vehicle.
- H) Moving parts must be shielded. Always maintain at least 10 meter [30'] distance from the Cargo Floor system when it is in operation.
- I) In the event of malfunctions/maintenance work, you may approach the Cargo Floor system only if all equipment, including the hydraulic pump, have been shut off, and the Cargo Floor system and the electro-hydraulic aggregate have been disconnected from the power supply and pump.
- J) Regularly check and, if necessary, tighten any loose bolts that secure the aluminium floor profiles to the Cargo Floor system. All such checks can simply be performed inside the vehicle itself by qualified personnel. The Cargo Floor system must, however, be turned on in unloaded condition and the person performing the check must place his finger half on the floor profile and half on the bolt. There should be no appreciable movement/space between the floor profile and bolt. Failure to check these bolts may lead to damage to the Cargo Floor system. During this check, a second person must also be present to switch off the Cargo Floor system.
- K) Check that the minimum required amount of oil is present 150 liter [40 US gallon]. Too little oil in the hydraulic tank will cause damage to both the pump and the Cargo Floor system.
- L) Do not allow the number of strokes to exceed the maximum allowable 16 power strokes per minute. Only a CF500 SLC Power Speed Cargo Floor system may deliver up to 23 beats per minute. A higher number of power strokes can cause damage to the Cargo Floor system and the vehicle.
- M) Hydraulic lines, couplings and hoses with very small diameters will cause damage.
- N) If the Cargo Floor system fails to start or operates incorrectly, the Cargo Floor system and the hydraulic pump must be shut down immediately. Subsequently, check all the checkpoints before switching the pump and the Cargo Floor system back on. To prevent the oil from overheating, regularly check the oil temperature by CAREFULLY and CAUTIOUSLY touching the line and or oil tank. If either is too hot to the touch, stop touching them right away. **WARNING: TOUCHING OVERHEATED OIL AND COMPONENTS CAN CAUSE BURNS!**
- O) The cause of failure or malfunctioning of the Cargo Floor system may also be due to other hydraulic components that may or may not be connected to the same hydraulic circuit of the Cargo Floor system.
- P) Jamming of the floor profiles caused by the transport of abnormal loads and or the freezing of the floor or of the product to the floor may result in damage to the Cargo Floor system and the vehicle. Recommendation: in the event of freezing, stop the system and try to find a hall (heated area) to allow the product to thaw.
- Q) Because the electrical power supply of the Cargo Floor system is often connected to the lighting circuit of the vehicle, it is advisable to turn on the lighting throughout the operation of the system.
- R) Maintenance and repairs to the Cargo Floor system may be only performed by qualified personnel. Use only original Cargo Floor components to ensure maximum reliability and long service life.
- S) Maximum cargo weight is subject to the limits set by law and applicable regulations. Even if the system can transport heavier loads, the law determines the maximum limit. Excessively heavy cargo can cause damage to the Cargo Floor system and the vehicle.
- T) Check that the correct type and quality of hydraulic oil is used. The use of incorrect oil type may cause damage to the Cargo Floor system and the pump.
- U) Check the vehicle for correct voltage. Make sure there are no open electrical connections. A faulty electrical system can cause damage to the Cargo Floor system and the vehicle.
- V) Check that the bulkhead, if present, is functioning smoothly and properly. A properly functioning bulkhead ensures that the product is unloaded in a clean and quick fashion. A malfunctioning bulkhead may extend the unloading time and cause damage to the vehicle.
- W) Use of the Cargo Floor system by unqualified personnel can cause damage to the Cargo Floor system and the vehicle.
- X) Excessively high oil temperatures will cause damage to the Cargo Floor system and other hydraulic components, such as the pump.

- Y) It is at all times advisable to stop the Cargo Floor system when all the piston rods are retracted. This is usually the case when the floor profiles are positioned towards the unloading end (vehicle doors). Unretracted piston rods may cause damage to the Cargo Floor system.
- Z) To prevent damage to the floor profiles, exercise caution and limit the dump height as much as possible. The transport of unauthorised goods, such as aggressive, corrosive, hot, hard, sharp and viscous materials may cause damage to the Cargo Floor system and the vehicle. Avoid loading and unloading sharp objects. Loads that are softer than the hardness of the floor profiles will extend the service life of your system; if in doubt, use a protective cloth or consult your dealer.
- AA) Forklift trafficable. In principle, the floors are completely trafficable and can be driven over by forklifts, but always consult your dealer for advice on the maximum loads allowed on your vehicle. Overloading will cause damage to the Cargo Floor system and the vehicle.
- BB) Always return emergency control(s) to their original non-activated position after use.
- CC) During the operation of the system, test the temperature of the oil by touching the side of the tank. If the oil is so hot that you cannot continue to touch the tank, switch off the pump to allow the oil to cool off and determine what is causing the overheating. Stop loading or unloading if the oil is too hot, as this will irreversibly cause damage to the Cargo Floor system and the other hydraulic components.  
**WARNING: TOUCHING OVERHEATED OIL AND COMPONENTS CAN CAUSE BURNS AND INJURIES!**  
Option: your Cargo Floor system could be equipped with an oil temperature safety switch which will switch off the system automatically when it starts to overheat.
- DD) During loading and unloading operations, the load should be spread to give an even weight distribution over the floor area, otherwise the load may stall. Tip: when transporting pallets, place soft-wood boards of 300 x 18 x 2350 mm. [12" x 0.75" x 92.5"] to distribute the pressure more evenly.
- EE) The constant pressing of the load against the head board or the doors can lead to extra wear of the complete system. Also the construction can be damaged. Please consult your supplier about the optimizing possibilities or in order to prevent problems occurring.
- FF) The user/operator/driver that is operating the Cargo Floor system is compelled to remain a safe distance from the Cargo Floor system at all times, from the time of switching on the hydraulic pump until turning it off. He should ensure that no dangerous situations can occur. When the process malfunctions or if other people are present he should shut down the Cargo Floor system, or hydraulic pump, immediately.
- GG) No unauthorized alterations/modifications/changes/adjustments may be made to any part of the Cargo Floor drive unit and system.

### **WARRANTY**

Warranty is subject to prior approval by Cargo Floor B.V.! To request warranty coverage, visit [www.cargofloor.com](http://www.cargofloor.com) to fill out and submit the warranty application form provided there; do not forget to include your Cargo Floor system number on the form.

### **EMERGENCY STOP**

In the event of an EMERGENCY, operation of the Cargo Floor system can be halted as follows:

- By pressing the red stop button on one of the control switches;
- By turning all switches to position "0";
- By putting the handle of the control valve in the middle "0" position (only B and A control);
- Turning off the PTO pump/engine;
- Turning off the main switch of the power supply;
- Turning off the motor of the electro-hydraulic aggregate.

**INTELLIGENT REMOTE CONTROL MODULE (IRCM)**



**CHECK BEFOREHAND!**

**BE CAREFUL:** When the pump/PTO is switched on, the system may start moving immediately! With certain versions, the functions may differ from the standard situation, which is described below. It is therefore important to always test your version without a load first.

**Scope of supply**

Set 3 functions IRCM, part number 6104050.01

This set consist of

- A: 6104048 IRCM receiver
- B: 6104047 IRCM Remote Control
- C: 5154038 IRCM Receiver mounting bracket Control box/trailer incl. fastening material
- D: 6401097 IRCM Receiver cable set incl. Hirschmann+ 3 Deutch connectors for connection to the CF7 switch

**A:**



**B:**



**C:**

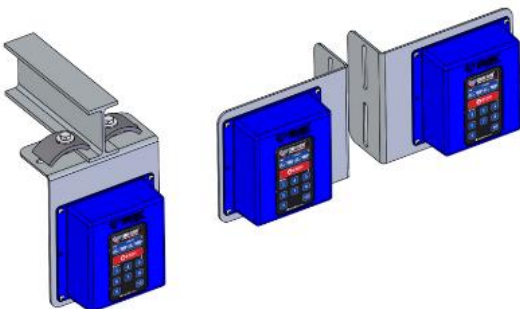

**D:**





**IRCM RECEIVER**

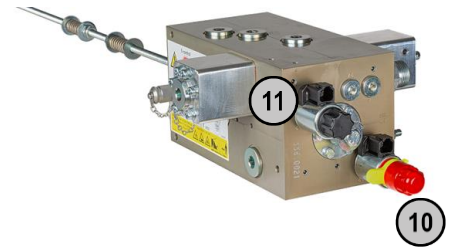
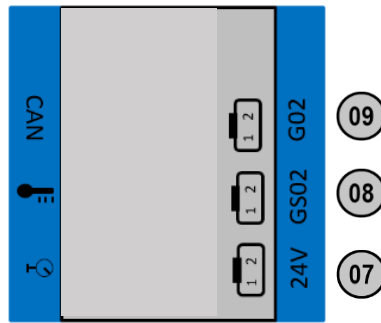

- |    |                          |    |                                      |
|----|--------------------------|----|--------------------------------------|
| 01 | Button loading           | 07 | Connection power supply              |
| 02 | Button unloading         | 08 | Connection GS02 (cartridge red cap)  |
| 03 | Button stop              | 09 | Connection G02 (cartridge black cap) |
| 04 | Buttons 3 to 10          | 10 | Cartridge GS02                       |
| 05 | LED power supply         | 11 | Cartridge G02                        |
| 06 | LED Bluetooth connection |    |                                      |

There are a number of connection points on the back of the receiver.

The power supply [07] will need to be connected to the power supply. The connection is connector Deutsch 2-pole.

The connection GS02 [08] will have to be connected to solenoid GS02 [13], the connection is a cable fitted with 2x connector Deutsch 2-pole.

Connection G02 [09] will be connected to an E-controlled control valve, the connection is a cable provided with 2x connector Deutsch 2-pole.

The receiver is equipped with a control panel with the buttons load [01], unload [02], stop [03] and buttons with numbers 3 to 10 [04]

Green Led: power supply [05]. Lit if power supply is present.

Blue Led: Bluetooth connection [06]

- slow blinking, the receiver is standby, no connection with remote control or phone
- lit continuously, the receiver is connected to remote control or telephone
- flashing, the receiver is in pairing mode



**Attention!!**

Plug at all 3 positions [07, 08, 09] connector Deutsch for a watertight seal.

**Technical data**

The power supply of the IRCM receiver is fully protected against:

- incorrect connection of the power supply
- voltage too low
- voltage too high
- over amperage

The IRCM receiver operates at a voltage of 9 to 33.5 volts.

The output voltage is in relation to the power supply.

**CONTROL THE IRCM RECEIVER WITHOUT A REMOTE CONTROL**



- 01 Button loading
- 02 Button unloading
- 03 Button stop
- 04 Buttons 3 to 10
- 05 LED power supply
- 06 LED Bluetooth connection

The IRCM receiver can be operated if the LED of the power supply [05] is lit green. When operating the Load, Unload and or Stop buttons, a vibration will be felt.

**Loading and unloading with the IRCM receiver**

**Button LOAD** By pressing the button load [01] the system will start loading, by releasing it the system will stop. The LED in the button simulates the loading function.

**Button UNLOAD** Pressing the unload button [02] the system will start unloading. The LED in the button simulates the unloading function. Pressing this button again will stop the system (or you press button STOP!).

**STOP button!** Pressing the Stop button [03] stops the system.



## IRCM REMOTE CONTROL



- 01 Button loading
- 02 Button unloading
- 03 Button stop
- 04 Buttons 3 to 10
- 05 LED low battery
- 06 LED Bluetooth connection

The remote control features Bluetooth technology and has two AAA batteries. The remote control is equipped with key illumination at the load/unload buttons if activated. When operating the buttons, a vibration will be felt. Do not put the remote control in your pocket to prevent unwanted operation and fast battery discharge.

### Switching the IRCM Remote Control on/off

Pressing any key will bring the remote control out of sleep mode. With the first actuation of any key, a vibration will be felt. If there is no Bluetooth connection, the blue Led will light up occasionally. The Remote Control returns to sleep mode after a few minutes if no function is operated.

If the Remote Control is switched on and has a connection to the receiver, the Bluetooth LED lights up continuously and a vibration can be felt every time a button is pressed.

### Loading and unloading with the IRCM Remote Control

**Button LOAD** By pressing the button load [01] the system will start loading, by releasing it the system will stop. The LED in the button simulates the loading function.

**Button UNLOAD** Pressing the unload button [02] the system will start unloading. The LED in the button simulates the unloading function. Pressing this button again will stop the system (or you press button STOP!).

**STOP button!** Pressing the Stop button [03] stops the system.

### Remote Control battery

At low battery voltage, power supply led will light up.

If the batteries need replacing, open the battery compartment on the back of the Remote Control with a flat or cross-head screwdriver and remove the cover. Replace the 2x 1.5V AAA batteries. Insert the batteries correctly into the remote control. For optimum performance, use alkaline batteries. Put the cover back in place and carefully screw it back on.

### Pairing the Remote Control to the IRCM receiver

If a Remote Control has not been paired with an IRCM receiver, the following procedure should be followed:

- A. Power IRCM receiver, hold the Remote Control within a range of 5 metres and turn it on by pressing a button
- B. IRCM receiver and Remote Control will then flash the bluetooth LED to indicate that the teach-on procedure has started
- C. Press button Stop, 9, 10, Stop on the IRCM receiver, now the bluetooth LED will blink rapidly
- D. Press button Stop, 9, 10, Stop on the Remote Control, now the bluetooth led will blink rapidly
- E. When both the Remote Control and the IRCM receiver have finished pairing, the bluetooth LED will no longer flash, but will on continuously.

**MOUNTING THE IRCM RECEIVER MOUNTING BRACKET TO THE CONTROL BOX**

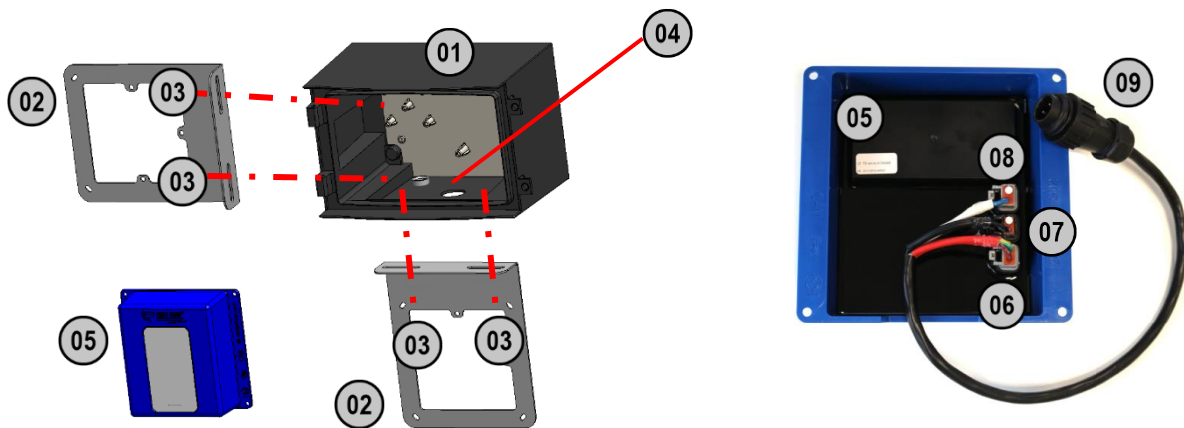

- |    |                                      |    |                         |
|----|--------------------------------------|----|-------------------------|
| 01 | Control box                          | 06 | Cable sleeve red 24V    |
| 02 | Mounting bracket                     | 07 | Cable sleeve black GS02 |
| 03 | Drill 8 mm hole for mounting bracket | 08 | Cable sleeve white G02  |
| 04 | Drill feed-through hole 25-30 mm     | 09 | Hirschmann plug         |
| 05 | IRCM receiver (rear side)            |    |                         |

Mounting IRCM receiver mounting bracket to the Control box: sideways or at the bottom.

Use an 8 mm drill bit to drill the holes for the bracket through the Control box. Pay attention to the following:

- mount the mounting bracket so that the fastening lip of the bracket faces forward. This facilitates the tightening of the M8 bolts.
- for lateral mounting: the holes for fastening must be drilled completely through the double-skinned part of the Control box.
- The feed through-hole 25-30 mm at the bottom of the Control box is made to prevent water entry.
- ensure that the feed through-hole is drilled in the spot where the IRCM receiver cable set incl. Hirschmann and 3 Deutsch connectors for connecting to the CF7 take the shortest possible route.
- Lead the IRCM receiver cable set incl. Hirschmann + 3 Deutsch connectors through the feed through-hole.
- connect the IRCM receiver cable set incl. Hirschmann + 3 Deutsch connectors as follows:
  - connector with cable sleeve red to 24V
  - connector with cable sleeve black to GS02
  - connector with cable sleeve white to G02
  - Screw the Hirschmann plug onto CF7
- screw the IRCM receiver to the mounting bracket using the M4x10 stainless steel screw with locknut.

**IMPORTANT!**

- When dismantling and assembling the plugs of the receiver, prevent dirt and water from entering the plug.
- After installation, check - on site - whether the range of the remote control is enough to reach the base receiver.
- Do not drop the remote control.
- Never spray the electrical components with a high-pressure cleaner, this includes the remote control.
- For optimum reception of the basic receiver, mounting is recommended as far out as possible. We strongly advise against mounting the basic receiver in a steel housing.
- Preferably wear the remote control on a key cord. If the remote control is carried in the pocket, the buttons of the functions can be pressed unnoticed and the Cargo Floor system can be operated unnoticed.
- Make sure that at - all times - during loading or unloading you and your remote control are in reception range of the base receiver.
- In case of possible failures in the electrical system, the standard emergency control can be used to activate the functions on / off. Please refer to the operating instructions you received with your vehicle. It can also be downloaded from our internet site [www.cargofloor.com](http://www.cargofloor.com)
- Regularly check the following aspects carefully:
  - Damages to the housing;
  - Damages to the wiring or plugs.

## CONTACT DATA

### **Postal and visiting address:**

Cargo Floor B.V.  
Byte 14  
7741 MK Coevorden  
The Netherlands

Phone number: +31 524 593 900  
E-mail: [info@cargofloor.com](mailto:info@cargofloor.com)  
Website: [www.cargofloor.com](http://www.cargofloor.com)

### **Order spare parts:**

E-mail address: [sales2@cargofloor.com](mailto:sales2@cargofloor.com)  
DID number: +31 524 593 922

### **After Sales (technical questions and malfunctions)**

E-mail address: [as@cargofloor.com](mailto:as@cargofloor.com)  
DID number: +31 524 593 981 / +31 524 593 991

Coevorden, The Netherlands

© 2022 Cargo Floor B.V.

No part of this publication may be reproduced, stored in a retrieval system, or transmitted, in any form or by any means, electronic, photocopying, recording or otherwise, without the prior permission of Cargo Floor B.V.