

CARGO FLOOR®

ASSEMBLY INSTRUCTIONS

CF500 SLC BULKMOVER

CF500 SLC 15/156,8

Cargo Floor B.V.

World's leading manufacturer and supplier of horizontal loading- and unloading transport conveyor systems.

INTRODUCTION

The assembly instructions outlined in this book will enable you to assemble the Cargo Floor system you have purchased correctly. Every effort has been made, by means of diagrams and text, to ensure a clear and simple installation. To ensure the durability and reliability of this revolutionary loading and unloading system, it is important that you follow the assembly instructions as outlined in this book completely, and use quality materials in accordance with the specifications. Please note that the guarantee is only valid if the Cargo Floor system has been assembled in accordance with these assembly instructions. The latest available version can always be found on our internet site: www.cargofloor.com

The measurements given in this instruction start with the metric system after which between brackets [0] the imperial measurement is mentioned.

 **If the indications in this manual, as well as those stated in the user manual, are not followed this could result in damages and/or injuries.**

 **If your customer had any specific wishes we advise you to contact Cargo Floor B.V. This especially when what is wished for differs from the so-called normal use.**

(ADDITIONAL) INSTRUCTIONS

The following (additional) instructions are available:

- Assembly CF3 LP-2 15-160
- Assembly CF100 SLL
- Assembly CF500 SLC
- Assembly CF500 SLC Power Speed system
- Assembly CF500 SLC Leak Resist Centre drive
- Assembly CF500 SLC 15/156,8 [6.17"] XHDI / HD
- Assembly CF600 HDC
- Assembly CF800
- Assembly Protected Seal 156,8 mm [6.17"]
- Assembly Semi Leak Proof (SLP) system

The latest available version can always be found in the downloads section on our internet site:
www.cargofloor.com/en/downloads

TABLE OF CONTENTS

Introduction	2
(Additional) instructions	2
Table of contents	3
Important recommendations and guidelines	4
Emergency stop	7
Identification plate	8
Stickers	9
Hoisting instructions	11
The chassis	12
Mounting the plastic bearing strip at the back side	14
Mounting the (40x25x2 [1.6"x1"x0.08"]) rectangular tubes	15
Mounting the plastic bearing strip "Cargo Bulklover"	17
Positioning the system	18
Height adjustment and alignment of the Cargo Floor system	19
Securing the system	20
Bracing the side walls	22
Connecting the hydraulics	23
Choke	24
Mounting the plastic bearing "Cargo Twister WIDE 40/25"	25
Mounting the plastic bearing and anti lifting SPECIAL WIDE bearing 40/25	26
Cutting the floor profiles to size	27
Round off the profiles	27
Determine the position of the holes in the profiles	28
Drilling the holes in the floor profiles	29
Preparing the floor profiles and mount the floor seal	30
Mounting the endcaps	32
Securing the floor profiles to the drive unit	32
Securing the stationary side profiles	33
Sealing the front side of the floor	34
Mounting the control box and the electrics	35
The moving headboard	37
The moving headboard tarpaulin	38
Adjustment of the threaded rod of the control valve	39
Technical specifications	40
Maintenance instructions	41
Important instructions	42
Troubleshooting E-control	43
Warranty conditions	45
Contact data	47

TABLE OF CONTENTS OF THE ENCLOSED DRAWINGS

Attention: choose the system type that you are building in!!!

Subject	Drawing
System CF500 SLC H80-15-156,8, 12xM12	S1-156,8
System CF500 SLC H100-15-156,8, 12xM12	S2-156,8
System CF500 SLC H120-15-156,8, 12xM12	S3-156,8
System CF500 SLC H140-15-156,8, 12xM12	S4-156,8
Hydraulic drawing CF500 SLC A	H1-A
Hydraulic drawing CF500 SLC B	H1-B
Hydraulic drawing CF500 SLC E	H1-E
Proposal drawing hydraulic connections CF500 SLC	H2
Electric drawing E	E1
Electric drawing B	E2
Control valve	BV1
Control valve B	BV2

IMPORTANT RECOMMENDATIONS AND GUIDELINES

Before putting the Cargo Floor loading and unloading system into operation, follow the recommendations provided below and check the specified checkpoints to avoid damage to the Cargo Floor system and the vehicle.

Please review the important instructions before operating the Cargo Floor system and loading cargo into the vehicle. Likewise, before loading cargo, check the operation of the various control switches/valves to familiarise yourself with how the system works. We strongly recommend that you perform these checks when picking up the vehicle from the dealer so that your skilled supplier can answer your questions and provide you with any necessary advice or guidance you may require.

Important:

- Always check that the selected loading or unloading direction is actually activated and occurring!!
- If the system fails to start, turn off the Cargo Floor system and the hydraulic pump and follow the recommendations and guidelines provided below. Do not repeatedly try to start the system as this may result in damage to your Cargo Floor system and/or vehicle.
- After use, turn off the Cargo Floor system and hydraulic pump. Set switches to the "0" position and the lever in neutral.

In case of doubt or uncertainty about these recommendations and guidelines, always contact your dealer or an official workshop.

The Cargo Floor system comes standard with an operating manual, but if this has not been supplied, please contact your dealer or download it from the official Cargo Floor website: www.cargofloor.com, [download](#).

- A) Always open the vehicle's doors before turning on the hydraulic pump. Note! Build-up of pressure against the doors can open them with force. Also some of the cargo can fall out of the vehicle by itself after opening the doors, therefore KEEP CLEAR AT ALL TIMES, product could fall on top of you! Both could result in damages and/or injuries! It is always advisable to use the pneumatic door lock, if provided.
- B) 1. Check that the vehicle's (quick-detachable) couplings are properly connected to the P (Pressure line) and the T (tank/return line). Also check that the couplings are fully tightened or slid completely into each other.
IMPORTANT: the pressure and return line connectors may not be reversed or exchanged to prevent dirt or water from entering the lines when connecting them!
2. Before connecting, check that the non-return valves can open easily (check: the non-return valves should open easily when pressed with the finger, if not, potential pressure build-up in the hydraulic lines may be preventing the system from starting).
NOTE: Incorrectly connected or unopened hydraulic couplings will cause serious damage to the Cargo Floor system and the vehicle.
- C) The vehicle (pump) must be fitted with a pressure relief valve that is set at the maximum pressure according to the system, see the technical specs. If fitted, check that the dual-function lever (function: tipper/Cargo Floor) is in the Cargo Floor position. Pressure may not exceed the maximum adjusted and allowable operating pressure of the Cargo Floor system. An incorrectly adjusted pressure relief valve can cause damage to the Cargo Floor system and the vehicle.
- D) During operation, the (hand)brake of the vehicle must always be applied. You must, however, move the vehicle forward on time to unload it quickly in order to prevent unnecessary strain and wear to the floor and the vehicle.
- E) Use of a wireless remote control is permitted only if it is fully tested before the start of each loading or unloading operation. Always check if the function you have selected is actually activated and taking place. If, for example, you have accidentally pressed the load function when you actually meant to press the unload function, irreversible damage may occur to the Cargo Floor system and the vehicle.
- F) During operation of the Cargo Floor system, all existing STOP and control knobs/levers must be freely accessible.

- G) The pressure filter element needs to be replaced at least once a year. If the couplings between the vehicle and the Cargo Floor system are regularly removed, it is advisable to check the pressure filter for dirt build-up and replace the pressure filter element more often, if necessary. If provided, also check the return filter (not supplied with the Cargo Floor). Failure to replace a filter element on time may cause damage to or malfunctions in the Cargo Floor system and the vehicle.
- H) Moving parts must be shielded. Always maintain at least 10 meter [30'] distance from the Cargo Floor system when it is in operation.
- I) In the event of malfunctions/maintenance work, you may approach the Cargo Floor system only if all equipment, including the hydraulic pump, have been shut off, and the Cargo Floor system and the electro-hydraulic aggregate have been disconnected from the power supply and pump.
- J) Regularly check and, if necessary, tighten any loose bolts that secure the aluminium floor profiles to the Cargo Floor system. All such checks can simply be performed inside the vehicle itself by qualified personnel. The Cargo Floor system must, however, be turned on in unloaded condition and the person performing the check must place his finger half on the floor profile and half on the bolt. There should be no appreciable movement/space between the floor profile and bolt. Failure to check these bolts may lead to damage to the Cargo Floor system. During this check, a second person must also be present to switch off the Cargo Floor system.
- K) Check that the minimum required amount of oil is present 150 liter [40 US gallon]. Too little oil in the hydraulic tank will cause damage to both the pump and the Cargo Floor system.
- L) Do not allow the number of strokes to exceed the maximum allowable 16 power strokes per minute. Only a CF500 SLC Power Speed Cargo Floor system may deliver up to 23 beats per minute. A higher number of power strokes can cause damage to the Cargo Floor system and the vehicle.
- M) Hydraulic lines, couplings and hoses with very small diameters will cause damage.
- N) If the Cargo Floor system fails to start or operates incorrectly, the Cargo Floor system and the hydraulic pump must be shut down immediately. Subsequently, check all the checkpoints before switching the pump and the Cargo Floor system back on. To prevent the oil from overheating, regularly check the oil temperature by CAREFULLY and CAUTIOUSLY touching the line and or oil tank. If either is too hot to the touch, stop touching them right away. **WARNING: TOUCHING OVERHEATED OIL AND COMPONENTS CAN CAUSE BURNS!**
- O) The cause of failure or malfunctioning of the Cargo Floor system may also be due to other hydraulic components that may or may not be connected to the same hydraulic circuit of the Cargo Floor system.
- P) Jamming of the floor profiles caused by the transport of abnormal loads and or the freezing of the floor or of the product to the floor may result in damage to the Cargo Floor system and the vehicle. Recommendation: in the event of freezing, stop the system and try to find a hall (heated area) to allow the product to thaw.
- Q) Because the electrical power supply of the Cargo Floor system is often connected to the lighting circuit of the vehicle, it is advisable to turn on the lighting throughout the operation of the system.
- R) Maintenance and repairs to the Cargo Floor system may be only performed by qualified personnel. Use only original Cargo Floor components to ensure maximum reliability and long service life.
- S) Maximum cargo weight is subject to the limits set by law and applicable regulations. Even if the system can transport heavier loads, the law determines the maximum limit. Excessively heavy cargo can cause damage to the Cargo Floor system and the vehicle.
- T) Check that the correct type and quality of hydraulic oil is used. The use of incorrect oil type may cause damage to the Cargo Floor system and the pump.
- U) Check the vehicle for correct voltage. Make sure there are no open electrical connections. A faulty electrical system can cause damage to the Cargo Floor system and the vehicle.
- V) Check that the bulkhead, if present, is functioning smoothly and properly. A properly functioning bulkhead ensures that the product is unloaded in a clean and quick fashion. A malfunctioning bulkhead may extend the unloading time and cause damage to the vehicle.
- W) Use of the Cargo Floor system by unqualified personnel can cause damage to the Cargo Floor system and the vehicle.
- X) Excessively high oil temperatures will cause damage to the Cargo Floor system and other hydraulic components, such as the pump.

- Y) It is at all times advisable to stop the Cargo Floor system when all the piston rods are retracted. This is usually the case when the floor profiles are positioned towards the unloading end (vehicle doors). Unretracted piston rods may cause damage to the Cargo Floor system.
- Z) To prevent damage to the floor profiles, exercise caution and limit the dump height as much as possible. The transport of unauthorised goods, such as aggressive, corrosive, hot, hard, sharp and viscous materials may cause damage to the Cargo Floor system and the vehicle. Avoid loading and unloading sharp objects. Loads that are softer than the hardness of the floor profiles will extend the service life of your system; if in doubt, use a protective cloth or consult your dealer.
- AA) Forklift trafficable. In principle, the floors are completely trafficable and can be driven over by forklifts, but always consult your dealer for advice on the maximum loads allowed on your vehicle. Overloading will cause damage to the Cargo Floor system and the vehicle.
- BB) Always return emergency control(s) to their original non-activated position after use.
- CC) During the operation of the system, test the temperature of the oil by touching the side of the tank. If the oil is so hot that you cannot continue to touch the tank, switch off the pump to allow the oil to cool off and determine what is causing the overheating. Stop loading or unloading if the oil is too hot, as this will irreversibly cause damage to the Cargo Floor system and the other hydraulic components.
WARNING: TOUCHING OVERHEATED OIL AND COMPONENTS CAN CAUSE BURNS AND INJURIES!
Option: your Cargo Floor system could be equipped with an oil temperature safety switch which will switch off the system automatically when it starts to overheat.
- DD) During loading and unloading operations, the load should be spread to give an even weight distribution over the floor area, otherwise the load may stall. Tip: when transporting pallets, place softwood boards of 300 x 18 x 2350 mm. [12" x 0.75" x 92.5"] to distribute the pressure more evenly.
- EE) The constant pressing of the load against the head board or the doors can lead to extra wear of the complete system. Also the construction can be damaged. Please consult your supplier about the optimizing possibilities or in order to prevent problems occurring.
- FF) The user/operator/driver that is operating the Cargo Floor system is compelled to remain a safe distance from the Cargo Floor system at all times, from the time of switching on the hydraulic pump until turning it off. He should ensure that no dangerous situations can occur. When the process malfunctions or if other people are present he should shut down the Cargo Floor system, or hydraulic pump, immediately.
- GG) No unauthorized alterations/modifications/changes/adjustments may be made to any part of the Cargo Floor drive unit and system.

WARRANTY

Warranty is subject to prior approval by Cargo Floor B.V.! To request warranty coverage, visit www.cargofloor.com, service to fill out and submit the warranty application form provided there; do not forget to include your Cargo Floor system number on the form.

EMERGENCY STOP

In the event of an EMERGENCY, operation of the Cargo Floor system can be halted as follows:

- By pressing the red stop button on one of the control switches;
- By turning all switches to position "0";
- By putting the handle of the control valve in the middle "0" position (only B and A control);
- Turning off the PTO pump/engine;
- Turning off the main switch of the power supply;
- Turning off the motor of the electro-hydraulic aggregate.

IDENTIFICATION PLATE

General extended identification plate

Next to the system number the Cargo Floor order number will be mentioned and a field with 9 digits has been added in which we can, if required, put your identification or order number.

Numbers are automatically provided with a barcode; this makes it possible for you to scan the required data.

Short small identification plate

An extra identification plate has been mounted near the rear bridge, above the threaded rod of the control valve, so the system number can be read simply and swiftly at the outside of the trailer.

Paint and dirt protection

The identification plates are specially fitted with a double layer of transparent protective foil. The first protective foil has a lip with remains visible when the Cargo Floor system has gotten painted or exceptional dirty. This protective foil can simply be removed so the data is readable again and the second protective foil remains intact so the data remains protected.

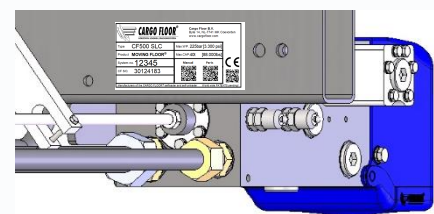
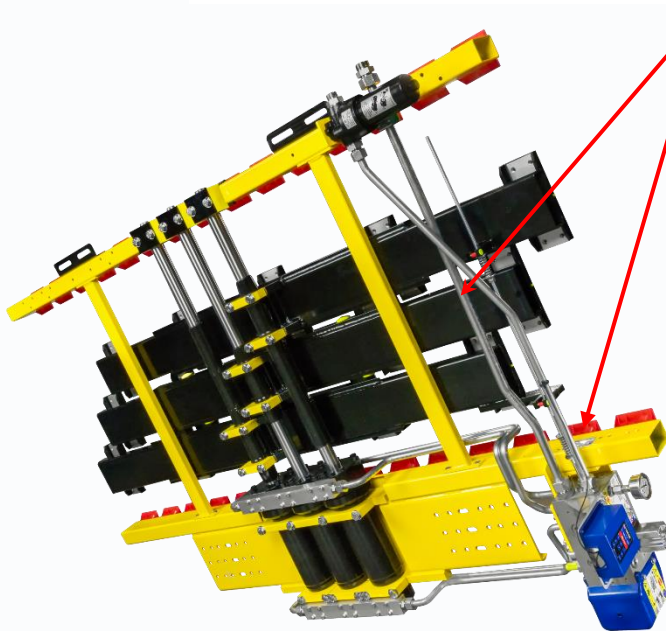

STICKERS

This WARNING STICKER/DECAL has been supplied with the drive unit in two fold. It should be attached near the control box and on the rear door in such a way that it is easy to read.



STICKERS/DECALS ON THE TRAILER

A



B

White/transparent



Black/ transparent



or

C

STICKERS/DECALS ON THE CONTROL BOX, ONLY WITH B- AND E-CONTROL



STICKERS/DECALS ON THE SWITCHES

Switch B-control

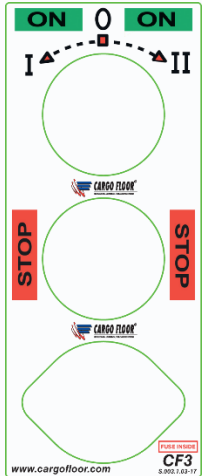

Switch B-control

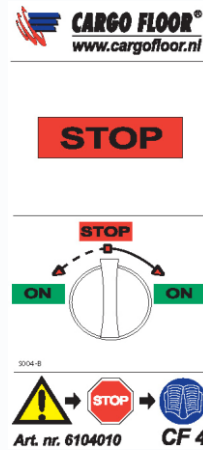

Switch E-control

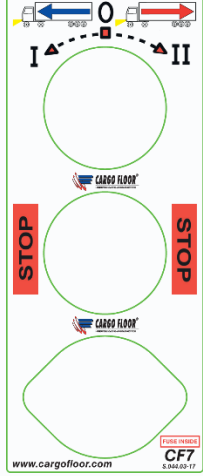

Switch E-control

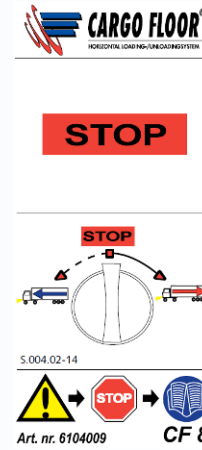

D

STICKERS/DECALS ON THE SIDE OF THE TRAILER, NEAR THE DRIVE UNIT

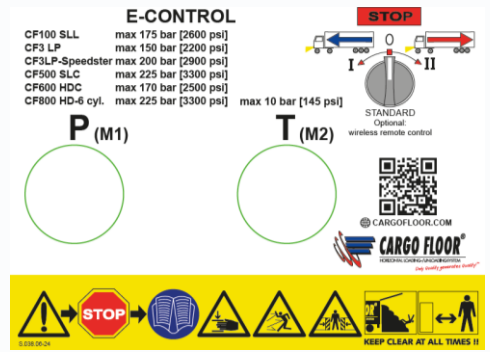
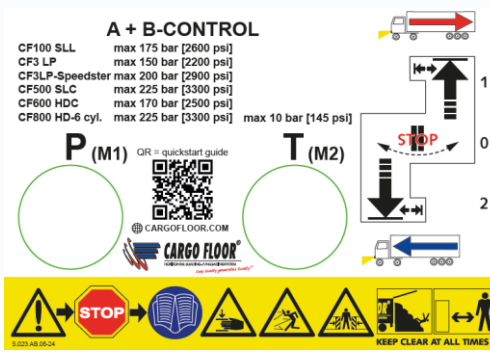

Only A + B-control



HOISTING INSTRUCTIONS

Attention!

If your system has been supplied with piston rod protection, this protection needs to remain put until the end of the mounting process. It may only be removed just before you hand over the trailer to your customer.



Warning!

It is not permitted to lift the Cargo Floor system by the cylinders, moving crossmembers, valves or pipes.

You must use the hoisting points when lifting the Cargo Floor system (as shown in figure 2). You need to pay particular attention that you use the right set of hoisting tools during lifting so that the bearings and conduits do not get damaged.

Systems supplied in transport rack

The tilting plates mounted at the rear bridge are designed in such a way that they prevent damages occurring to the cylinder bottoms, conduits and valve when tilting the system onto blocks or directly onto the chassis.

Systems supplied on pallet

The Cargo Floor system can be mounted directly on the chassis. Great care must be taken while placing the Cargo Floor system to ensure that the system cannot slide away and cause danger and that there is absolutely no damage caused to the system.

FIG. 2

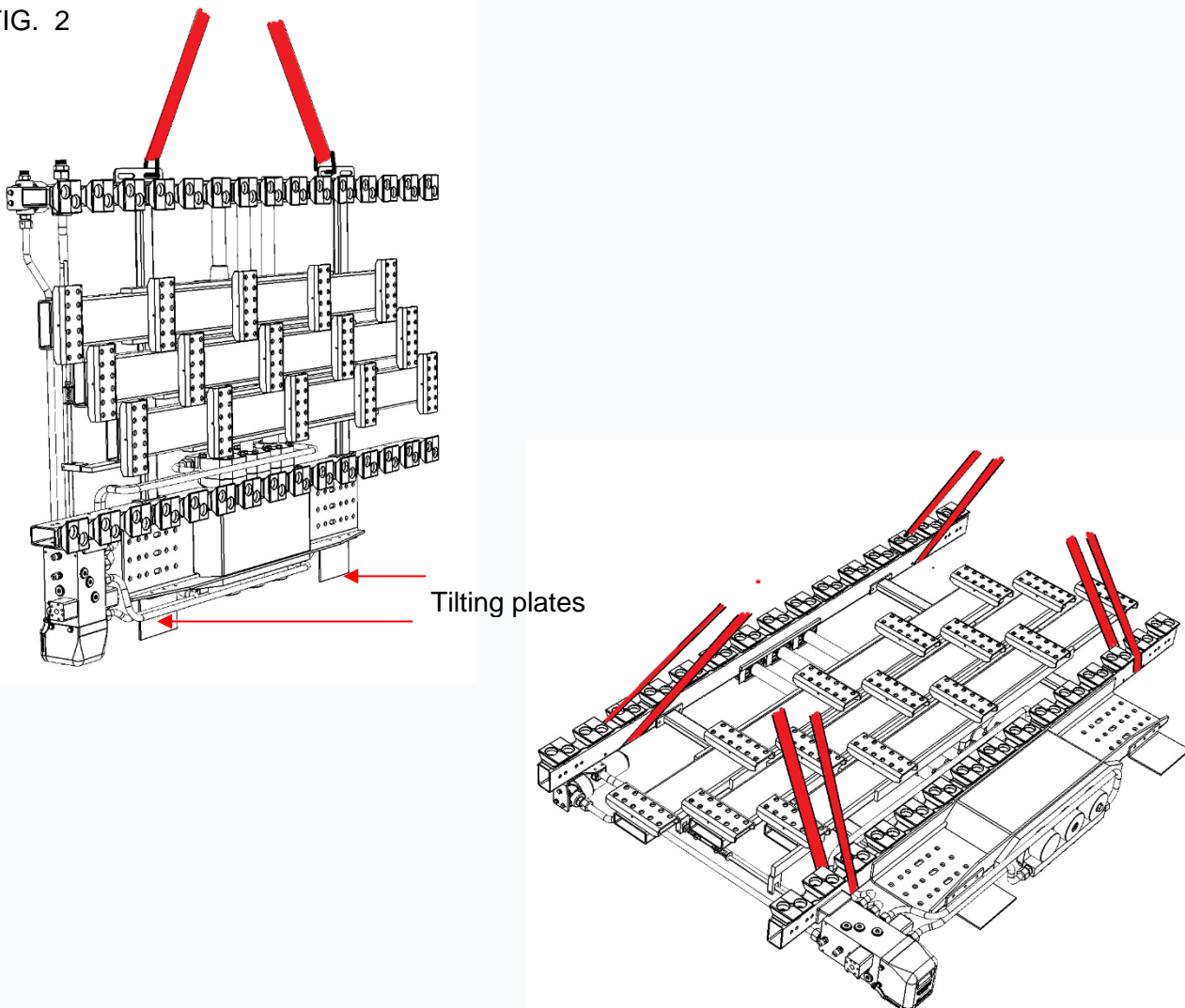

THE CHASSIS

It's very important to ensure that, during the installation of the Cargo Floor system, the crossbeams are flat on the chassis. There must be no difference in height between the crossbeams, as this would hinder the installation of the system and adversely affect the operation and the lifetime of the Cargo Floor system.

FIG.3

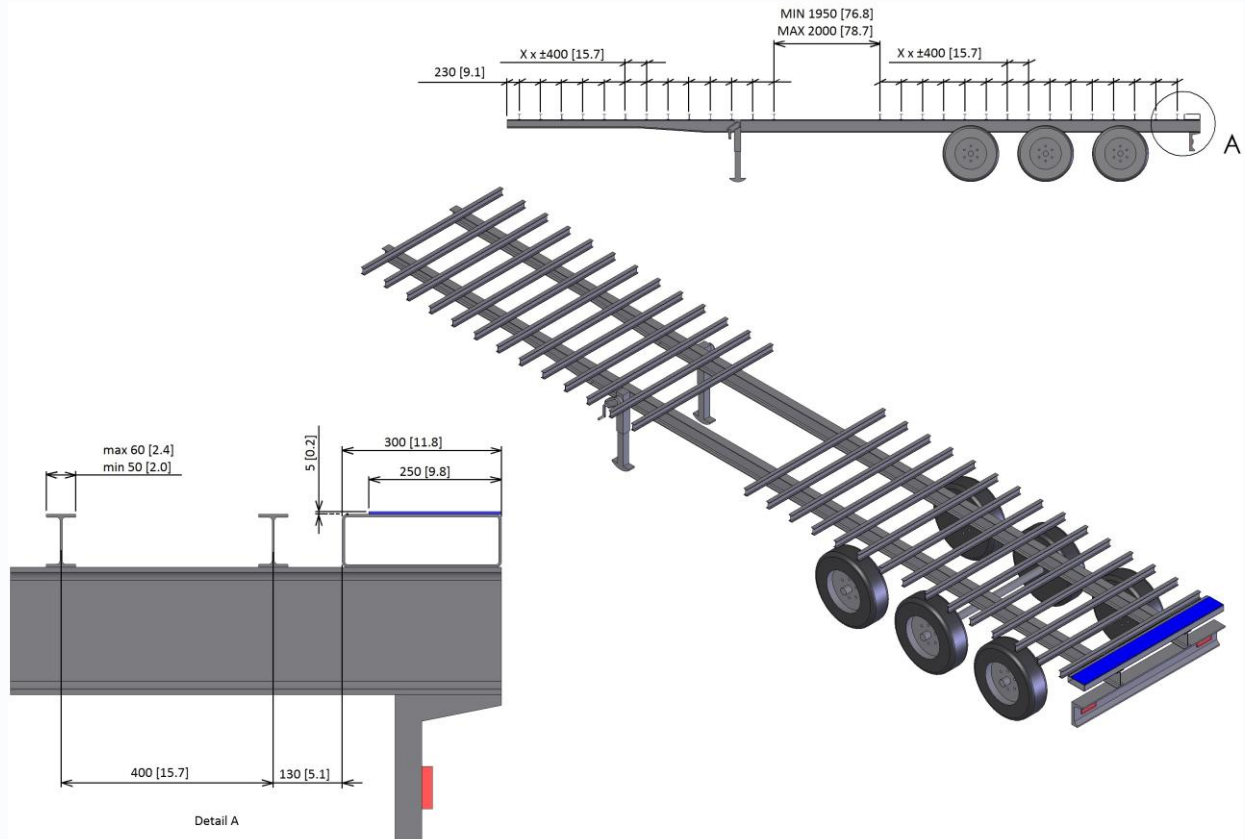

When using the plastic bearing on the rectangular tube 40x25x2 [1.6"x1"0.08"]

The top flange of the crossbeam may be a maximum of 60 mm [2.35"] wide and with a stabbed crossbeam the top flange must protrude at least 7 mm [0.28"] above the chassis beam, if this is the case use the Cargo Twister WIDE 40/25 (parts no. [4107031](#)).

If the flange of the crossbeam is larger than 60 mm [2.35"] but smaller than 120 mm. [4.7"] then the SPECIAL WIDE Bearing 40/25 (parts no. [4107034](#)) can be used.

When using the plastic bearing strip

The plastic bearing strip "Cargo Bulkmove" 3/156,8-H32 Red (parts no. [4107036](#)) can be mounted on every width cross beam with a minimal measurement of 50 mm.

Remark: We strongly advise you to apply a stable crossbeam when using this plastic bearing strip and also in the end area use an extra cross beam.

We refer you to figure 3 for the positions of the crossbeams for the various types of Cargo Floor systems. Make sure that there is space free in the middle of the chassis for the Cargo Floor system.

Make sure that you choose the correct system type*!

CF500 SLC **H 80** page S1-156,8 [6.2"] **H100** page S2-156,8 [6.2"]
 H120 page S3-156,8 [6.2"] **H140** page S4-156,8 [6.2"]

To finish the rear portal of the trailer, a solid and closed off supporting surface must be realized. This can be done by using: - a tube, - or folded sheet metal - or a plate between the cross members.

If a plate is chosen, it may not bend. Therefore, we advise to reinforce it. The upper surface must have at least a depth of 260 mm [10.2"], most bodybuilders take the fixed size of 300 mm [11.8"] for this. The wear plate will eventually be mounted on this.

The top of the supporting surface must be at exactly the same height as the top of the other cross members in the trailer.

A plastic wear strip of 2500 x 250 x 5 mm [98 "x10" x0.20 "] (article number [4101007](#)) should normally be mounted on this plate / tube. It is very important that the top of this wear strip is tightly/snugly fitted up against the bottom side of the moving floor profiles. This plastic plate functions as bearing, seal and wear plate under the floor profiles. The function of this plate is to wear down, based on fact that softer material will wear down and the harder material will not. When using a plate made of a harder material than the floor profiles, the softest material will normally wear first!



Attention!

It is not advisable to use a steel wear plate with floor profiles of the XD type! Due to the potential differences between steel and aluminum, an accelerated galvanic corrosion may occur!

MOUNTING THE PLASTIC BEARING STRIP AT THE BACK SIDE

In order to achieve an optimal sealing and prevent wear at the underside of the aluminium floor profiles or the rear portal a plastic bearing strip (parts no. [4101007](#)) needs to be mounted at the unloading side. Alternatively a stainless steel wear strip (parts no. 4148012) can be mounted on the rear portal to protect it from wear.

Mounting this strip is possible before mounting the floor profiles as well as after these have been mounted.

Attention: when determining the position of the plastic wear strip pay attention to if the door is in or outside the rear portal and mount the strip snug to the door.

The width of the wear strip should be at least 250 mm. [10"], length and thickness depends on your construction. In order to be able to simply swap this plastic bearing strip it needs to be mounted in the free part of the working stroke of the system. Determine, or have the system go to the front position, cylinders in the fully out position. Fasten the plastic bearing strip with 6.4x16.8 countersunk rivets with a range of 4 to 12 mm [0.2 – 0.5"] (parts no. [5017003](#)), so these do not come into contact with the moving floor. The stainless steel strip already has a hole pattern.

Put a small layer of sealant on the rear portal before mounting the plastic bearing strip, this prevents corrosion and dirt accumulating between the plastic bearing strip and rear portal.

After finishing the mounting of the plastic bearing strip, seal all the edges fully with sealant.

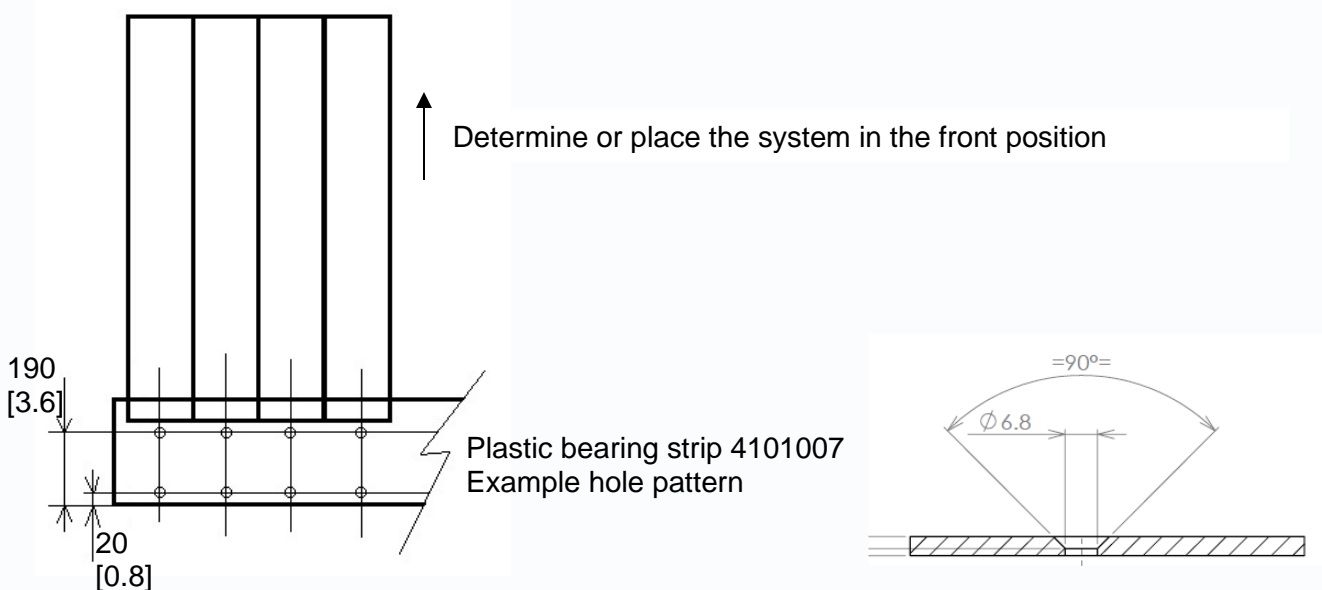

MOUNTING THE (40X25X2 [1.6"X1"X0.08"]) RECTANGULAR TUBES

A rectangular tube needs to be installed, over the full length and along the exact centre line of each of the crossbeams (fig. 4 A). The rectangular tubes need to be securely welded on both sides to each crossbeam with a weld of at least 20 mm [0.39"] length and thickness of 5 mm [0.20"] (as shown in figure 4 B).

Pay attention to that the start and end positions of the tube protrude far enough (50 mm [2"]) so the plastic bearing (Cargo Twister WIDE 40/25, parts no. [4107031](#)) can be mounted at that spot. (In fig. 4 A these are the details A-C and B-D.) This tube is used as a reference for the mounting of the other tubes with the help of the three welding jigs that have been supplied.

FIG. 4 A

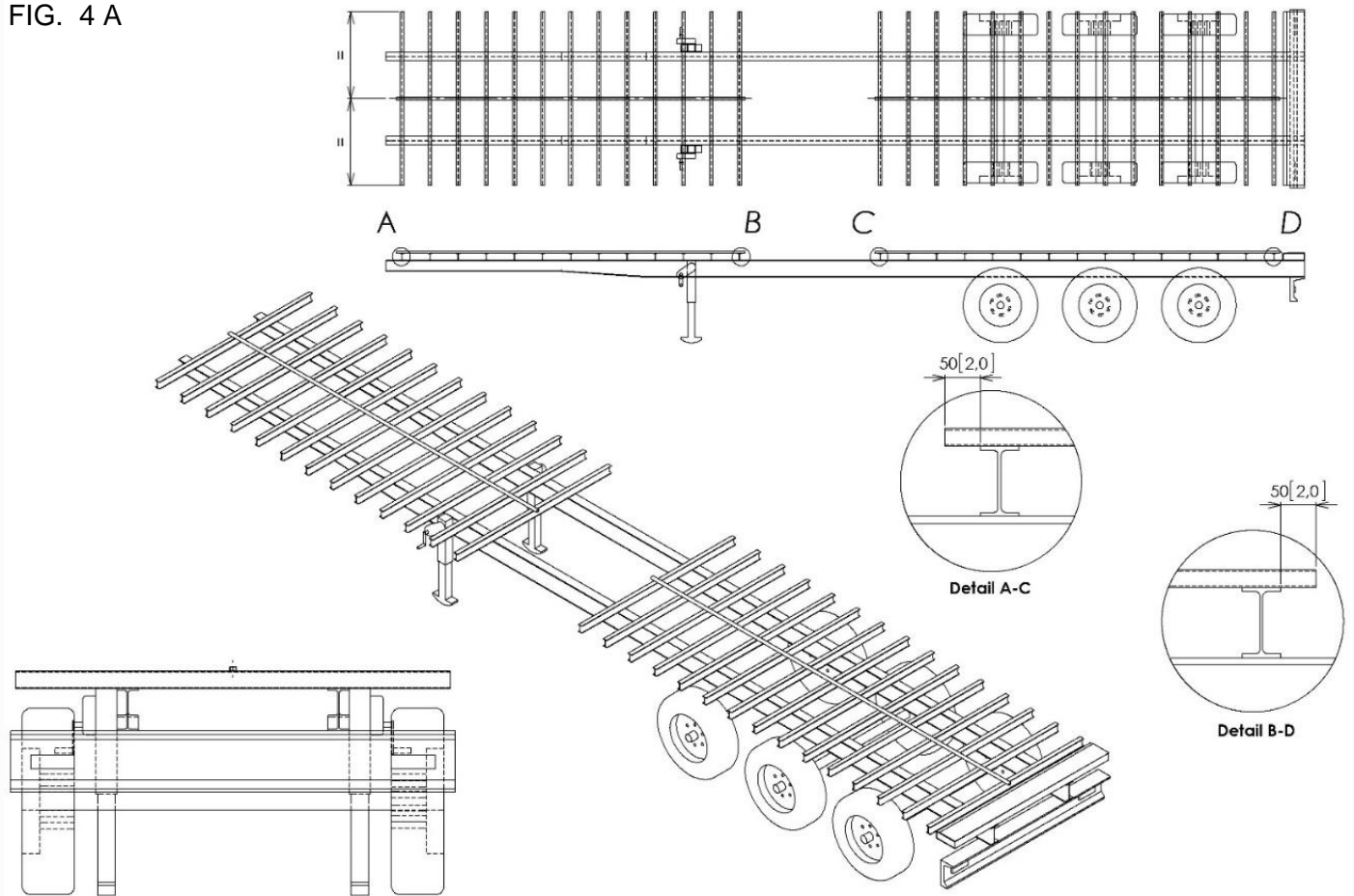

After this, all other tubes need to be mounted in exactly the same manner as the middle tube. Use the welding jigs (3 pieces, parts no. 9112008) for the right positioning of these tubes. All rectangular should be - onside and in the same direction - pushed into the welding jig. The jig needs to be fastened securely to the crossmember to no height differences can occur between the rectangular tubes. See fig. 4 B for positioning and use of the welding jigs.

FIG. 4 B

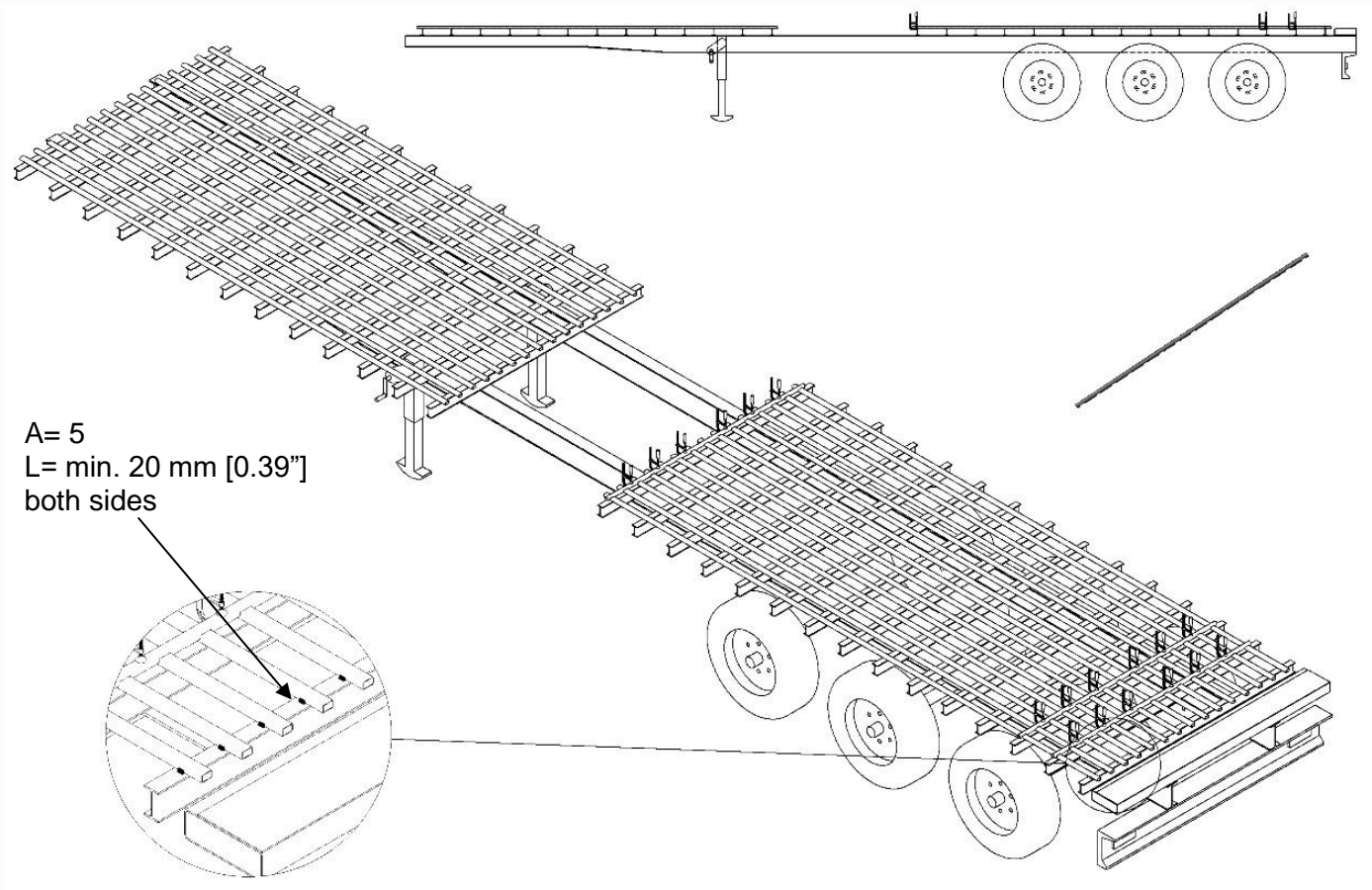

MOUNTING THE PLASTIC BEARING STRIP "CARGO BULKMOVER"

When using the plastic bearing strip "Cargo Bulkmove" 3/156,8-H32 Red (parts no. [4107036](#)) one should check beforehand if the height corresponds with the height of the drive system. Every strip has, on the bottom side, positioningslips, so every strip can be mounted easily and parallel to the cross member. The strip furthermore has been constructed in such a way that the floor profile can be clicked in from the top.

5 pieces of plastic bearing strip are mounted next to each other on a cross member. The centre line of the block in the middle of the strip needs to be mounted in the centre line of the chassis. The centre lines of the plastic strips are indicated on them.

When mounting the four outer strips one needs to measure anew from the centre line to the centre line of the block in the middle of the strip, or use the positioning jig 15/156,8 "Bulkmove" (parts no. 9111206).

We advise to use a cross member with a top flange of at least 50 mm. Every plastic strip should be fastened with the six available mounting points.

Note:

When using this plastic bearing strip we strongly advise you to use a stable cross member and to make sure that the under frame is strong enough. For the alignment, we do advise to use our mounting jig, parts no. 9111206.

Points of attention:

- Determine the center line
- Mount middle strip center line – center line
- Use all mounting holes available
- On the rear one can/may use an extra cross member

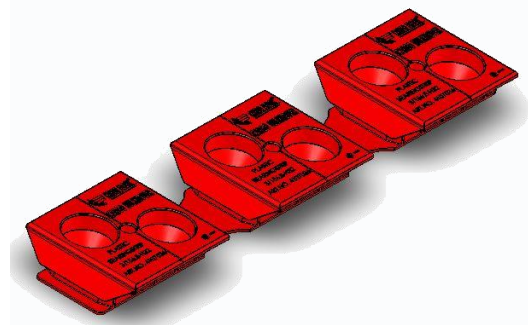
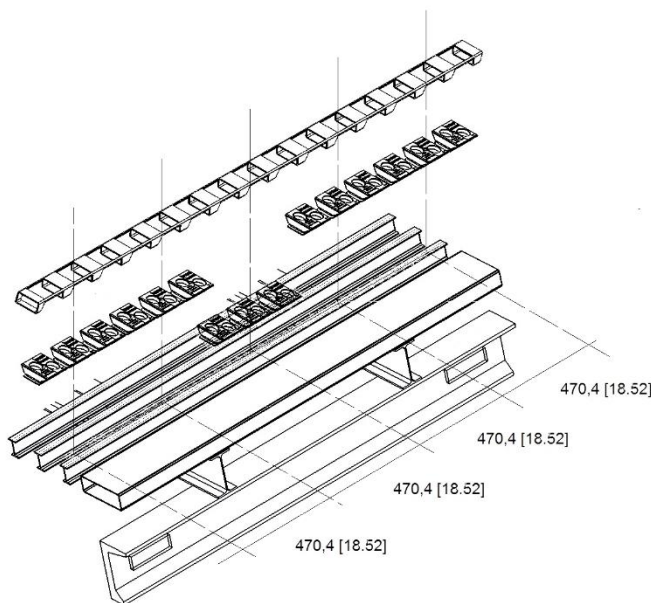

POSITIONING THE SYSTEM

The [hoisting procedures](#) need to be studied before placing the CF500 SLC BULKMOVER system. The CF500 SLC BULKMOVER system can now be laid in the appropriate opening on the chassis / frame (see figure 5), **noting that the piston rods must always point in the head board direction.**

FIG. 5

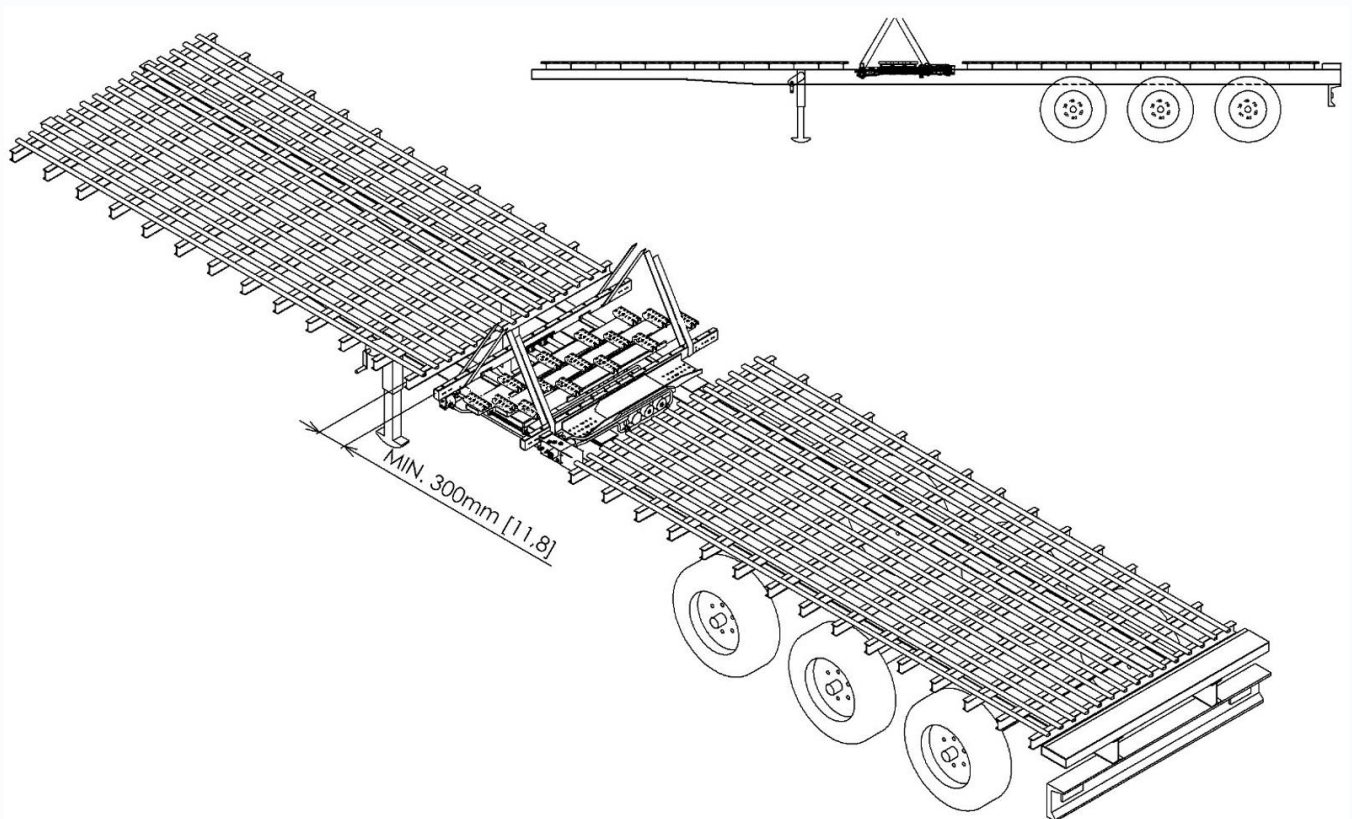

HEIGHT ADJUSTMENT AND ALIGNMENT OF THE CARGO FLOOR SYSTEM

Height adjustment

The Cargo Floor system needs to be at the same height as the plastic bearing that are mounted on the crossbeams. The top of the U- profile of the moving crossmember (U-fasteners for the floor profiles, see figure 6) is the reference. Any extra spaces that have been created between the chassis / frame and the underside of the Cargo Floor system should be filled.

Alignment

It is extremely important that the Cargo Floor system is exactly lined up with the plastic bearing. The piston rod of the middle cylinder is used as reference for this. The centre line of the moving crossmember finger (U-fastener for the floor profiles) must be exactly in line with the centre line of the plastic bearing mounted on the crossbeams.

It is advisable to clamp the Cargo Floor system securely once it is correctly positioned.

FIG. 6

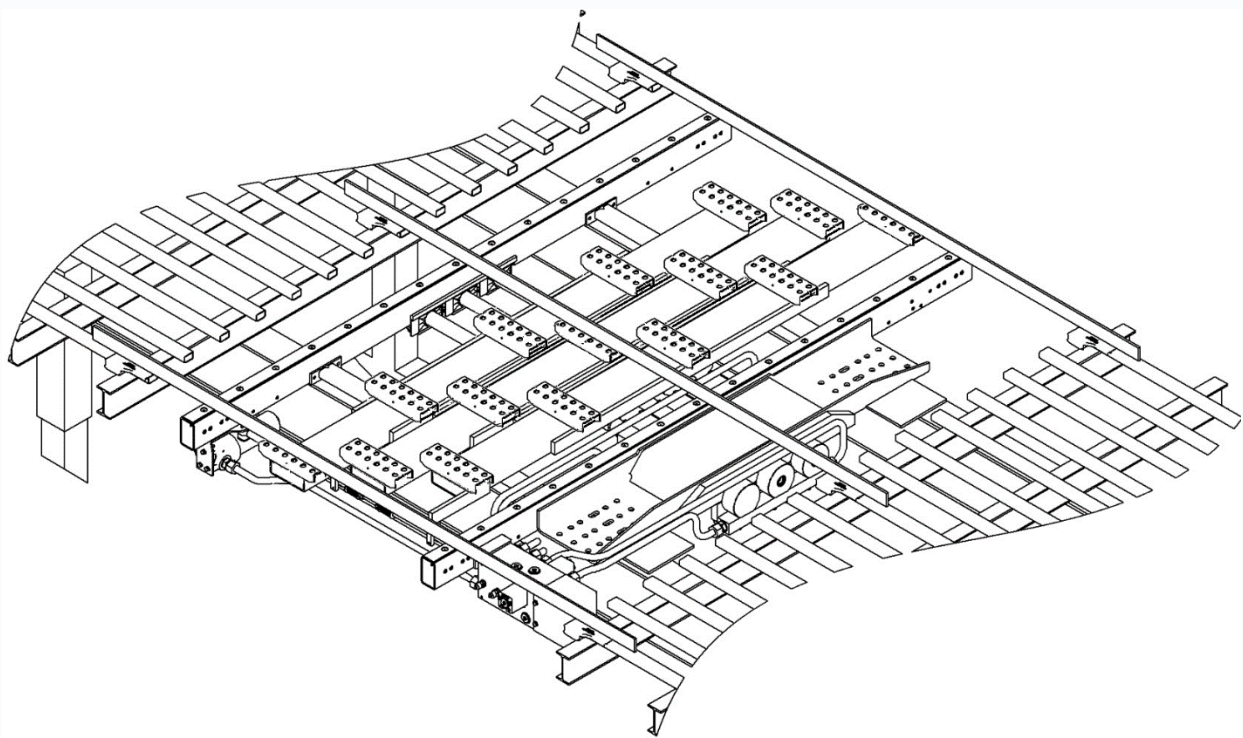
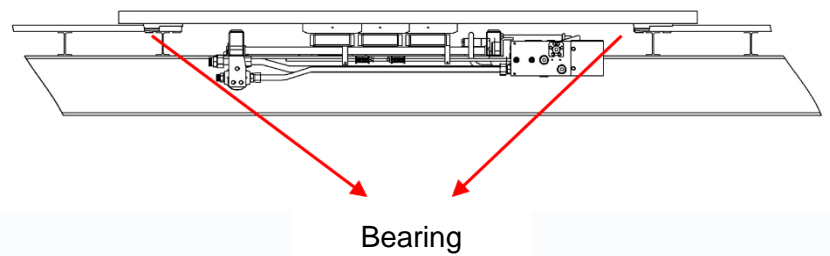

SECURING THE SYSTEM

After the Cargo Floor system has been correctly positioned it can be secured to the chassis by welding or by bolting.

Bolting (see fig. 7 and 8), mounting kit Cargo Floor (CF500/CF600)

The holes in the chassis should correspond with the mounting holes in the rear bridge and the front tube of the Cargo Floor system. 6 nuts per side need to be used on the rear bridge (see figure 7) and 1 nut per side in the so-called front bridge. This results in a total of 14 bolt connections. Each nut needs to be secured with a spacer and double nut (1x nut and 1x self-locking nut) (see figure 7).

All bolts must conform to the following specification:

14 pieces M16x80 ELVZ (DIN931-10.9) [5/8"x3.25"]. Quality 10.9. [grade 8].

14 pieces nut M16 [5/8"] Quality 10.

14 pieces lock/nut M16 [5/8"]

28 pieces washer Ø 30 / Ø 17, thick 3 mm (DIN125) [Ø 1.25" / Ø 0.75", thick 0.12"]

14 pieces spacer ST52-3 Ø 30 / Ø 17, length 20 mm [Ø 1.25" / Ø 0.75", length 0.79"].

8 pieces washer for heavy-duty slotted spring pin Ø 40 / Ø 17 x 6 zinc plated 200 HV

Where there is a slotted hole in the system, the washer for the heavy-duty slotted spring pin goes under the bolt head.

For an aluminium chassis we can advise, as an alternative to the spacers, to use a strip (thickness 20 mm [0.79"]) with corresponding hole pattern.

Torque of the M16 nuts is 300 Nm [215 lbf.ft].

FIG. 7

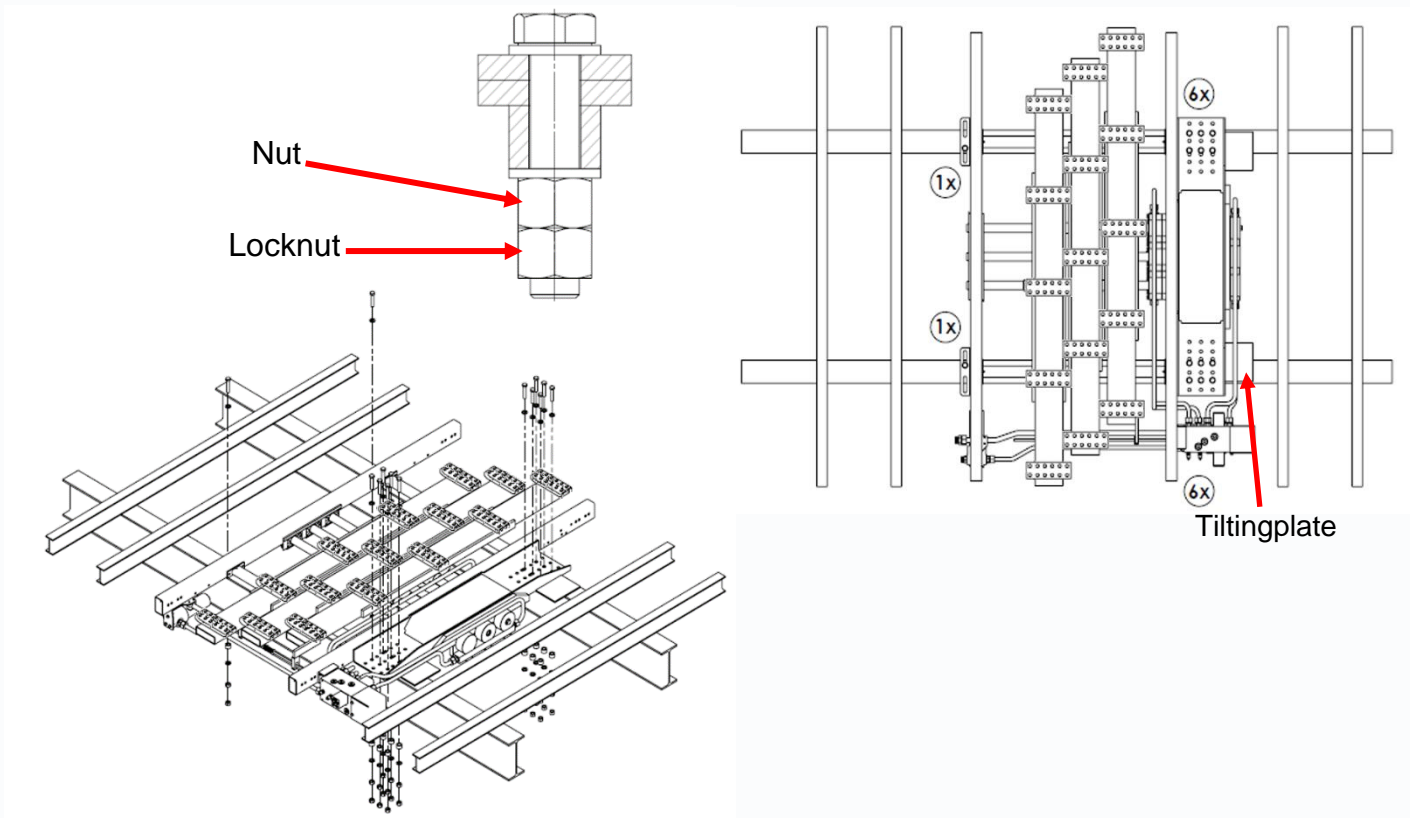

Welds (see fig. 8)

Good quality welds, of the appropriate lengths, need to be made at the points indicated in the drawing (figure 8).

The tilting plates (if present) at the rear side of the rear bridge need to be removed before welding the rear bridge to the chassis (figure 7).

Use a weld width of min. $a = 10$ [$a = 0.5''$].

Bracing of the Cargo Floor system is not necessary.

Attention!

If the sub frame is zinced (option) the surfaces that need to be welded should have the zinc coating removed.

FIG . 8

Weld all 8 welds over the full length.

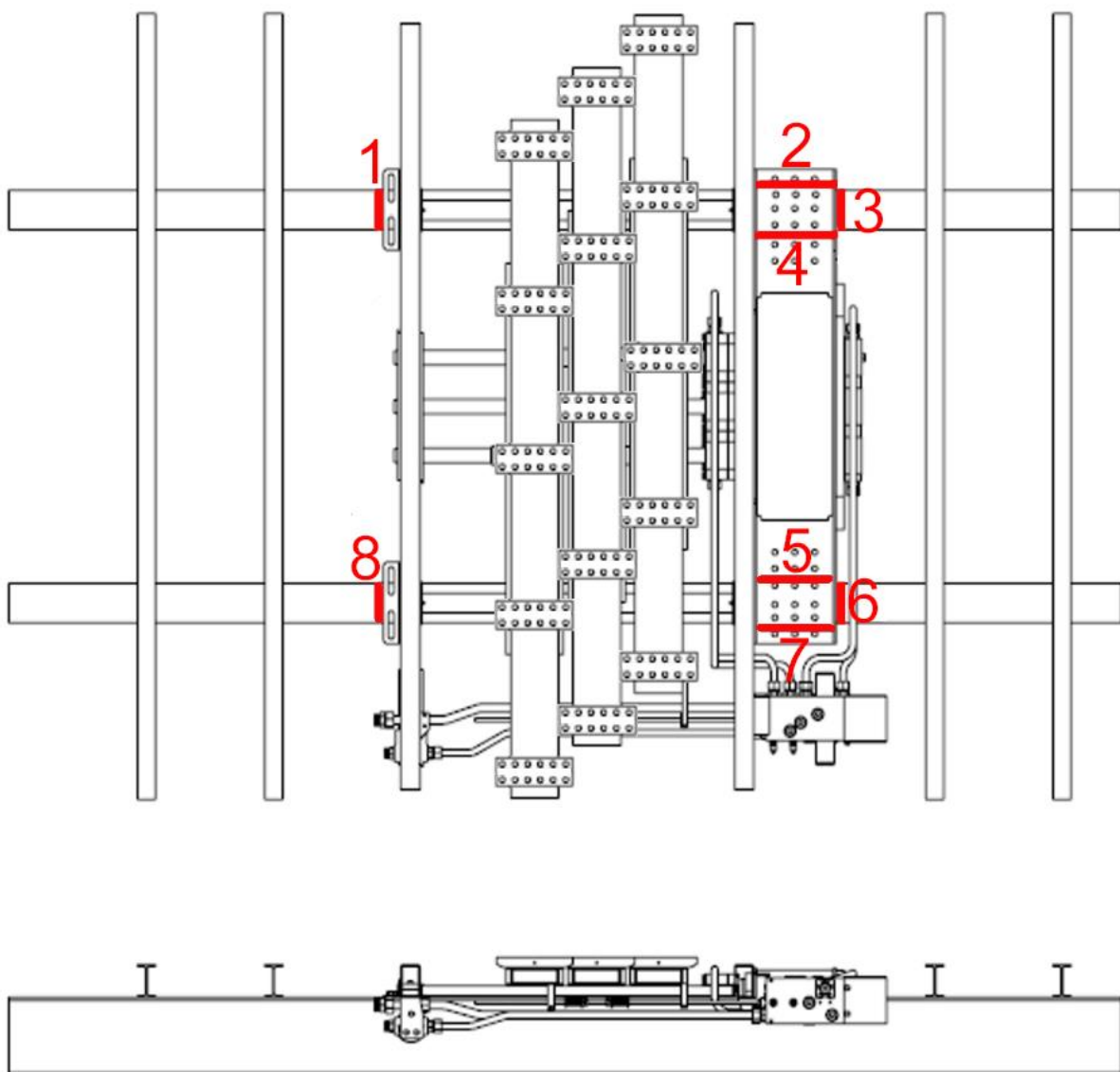

BRACING THE SIDE WALLS

The sidewalls of the Cargo Floor system are not supported since no crossbeams are used. This can lead to buckling of the sidewalls when the system is heavily loaded. This can be avoided by fastening the sidewalls to the chassis. Figure 9 shows how this can be done.

FIG. 9

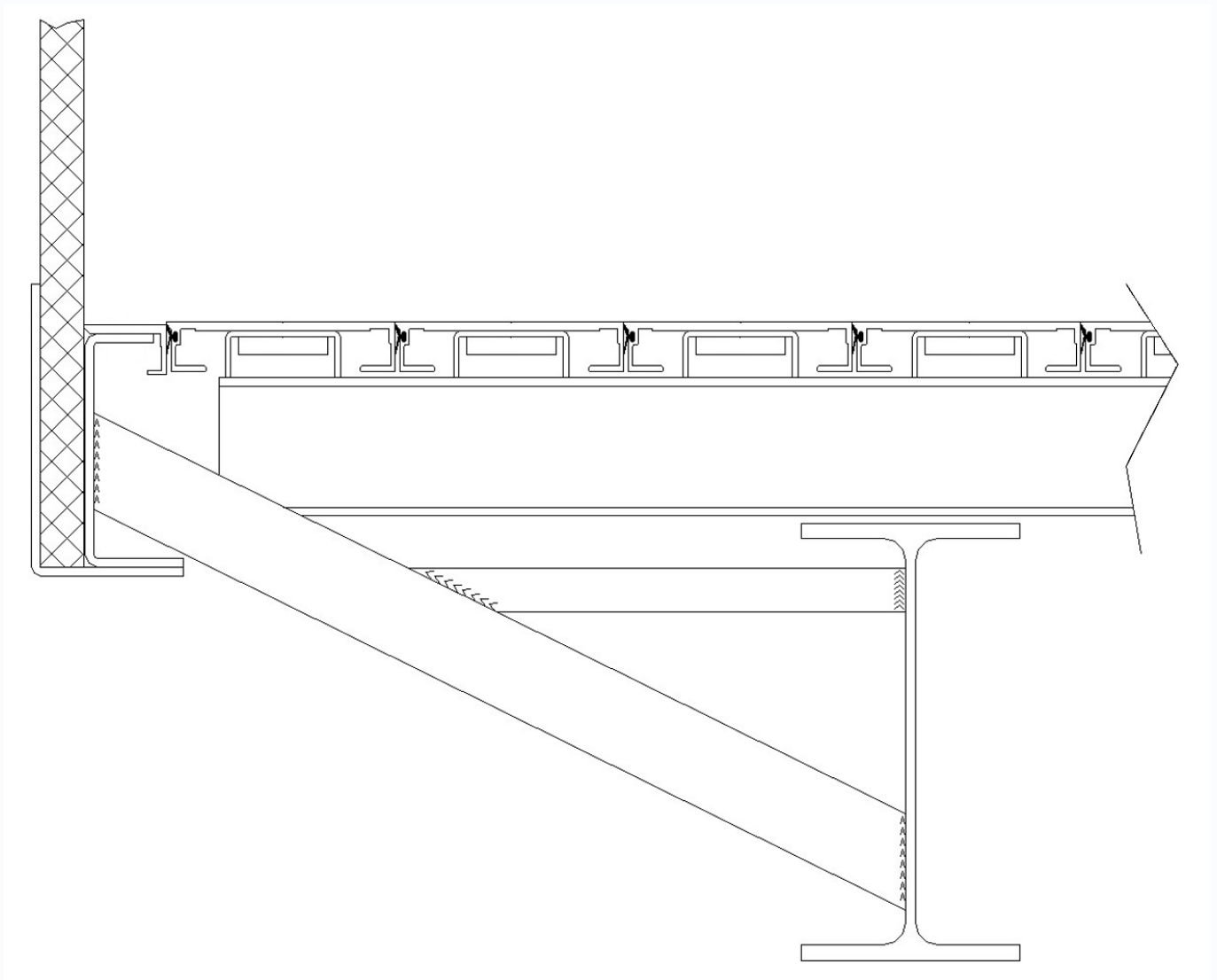

CONNECTING THE HYDRAULICS

The Cargo Floor system is supplied as standard with a pressure filter already mounted on the front bridge, see figure 10. There is a hydraulic pressure pipe (Ø 20 x 2 feed through 16 mm) already mounted from the control valve to the pressure filter. The 'in' channel of the pressure filter is provided with a straight screw-in coupling 1" x 20 mm. (Other types of couplings are optional) Next to this is a hydraulic return pipe (Ø 25 x 2,5 feed through 20 mm) mounted from the control valve to the front bridge, ending in a straight connecting coupling 25-25 mm. You can connect the required hydraulic hoses (not included in delivered package) directly to these connectors (the supplied turnbuckles and cutting rings are not required then). If you mount a hydraulic pipe instead of hydraulic hoses then you can use the turnbuckles and cutting rings.

⚠ Important: connecting pressure and return wrongly will cause a malfunction, and damage to, the system.

All hydraulic components need to be carefully cleaned before being connected, making sure that no sealing caps / cleaning wads are left behind.

Try to use as few (square-)angled couplings as possible (as these cause pressure loss, or build-up of return pressure).

After connecting the system it may not be operated. Operation may only be done at the moment that the trailer and floor have been fully built!!!!

FIG. 10

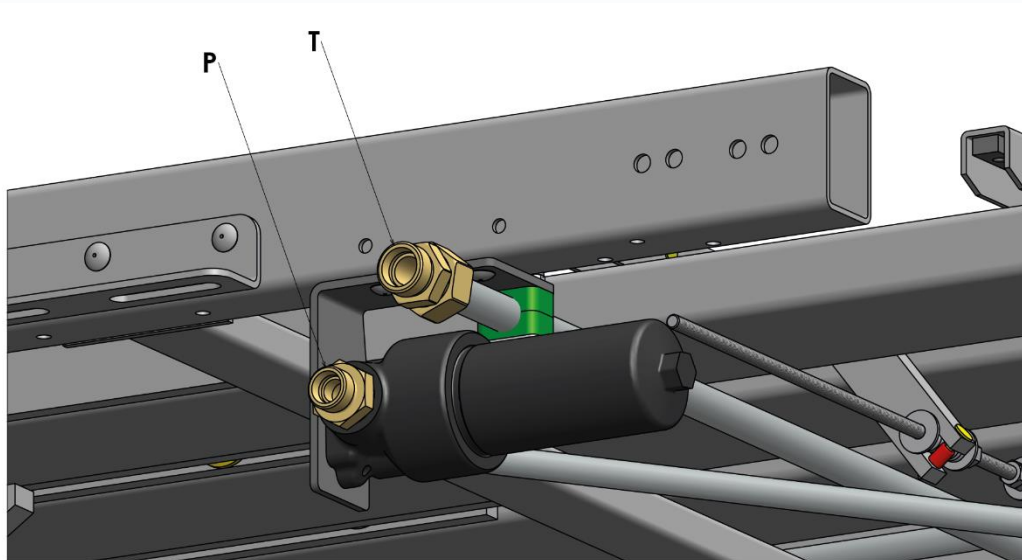

CHOKE

If the E-controlled Cargo Floor system will be operated by different types of pumps or a pump with a low oil flow, it could be that you have to pay attention to mount another type of choke.

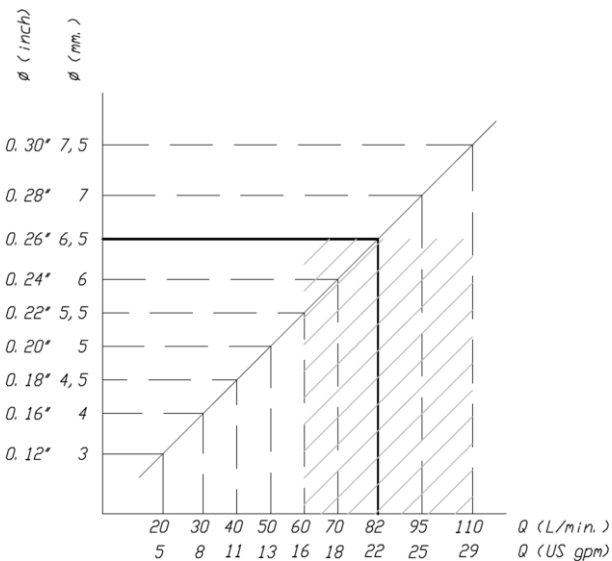

The shading points out the reach of the standard choke.

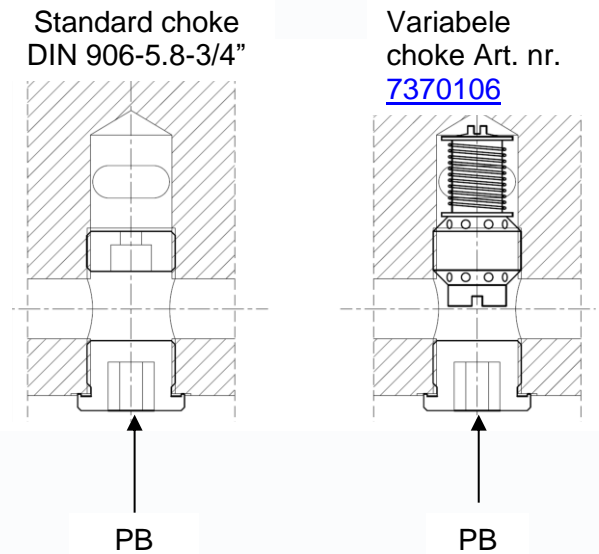

Choke

There is a standard 6,5 mm [0.26"] choke mounted as standard in the PB channel of the E control valve. This allows the E control valve to function correctly. This standard choke is suitable for an oil flow level of 60 to 110 litres per minute [16 to 29 gpm]. The function of the control valve can be affected by a deviation from this oil flow level. The oil flow diagram shows which level of oil flow is required by which opening. Adjustment of this is possible by simply changing the diameter of the choke.

Known consequences of a wrong choke diameter are:

- Oil flow too low: load/unload operational plunger is not switching, system gets pressure less;
- Oil flow too high: noise in system, high heat dissipation and capacity loss.

Flow independent choke

As an option a flow independent choke can be supplied (variable choke article number 7370106). The standard mounted choke can simply be changed with these. You remove the socket plug out of channel PB (Allen key 12 mm). After this you screw the choke out of the channel with Allen key 12 mm. Screw the new variable choke in the channel and fasten these by hand (about 15 Nm [11 lbf.ft.]). Screw the socket plug back into channel PB (Allen key 12 mm) and fasten these by hand (about 15 Nm [11 lbf.ft.]). Let the floor run (loading and unloading) in order to check if everything is functioning well and no leakage occur. The variable choke has a flow range of 20-120 ltr./min [5-31 gpm] $\pm 10\%$ using a VG32 and is suitable for a maximal work pressure of 225 bar [3300 psi].



Important!

Connecting pressure and return wrongly will cause a malfunction, and damage to, the system.

B-control

Another possibility to be independent from a variable oil flow is using a B-control. With this the loading/unloading direction is determined by a handle.

MOUNTING THE PLASTIC BEARING “CARGO TWISTER WIDE 40/25”

After the rectangular tubes (40x25 mm [1.6"x1"]) are spray painted (pay attention to that the tubes are not painted too thickly and surely do not have drops on them) the plastic bearings can be mounted. This can be easily done with one hand, without any tools, on the unique patented Cargo Twister WIDE 40/25. On each cross member the Cargo Twister WIDE 40/25 is placed diagonally over the rectangular tube and the bearing is rotated (twisted) through a quarter turn so that the feet of the plastic bearing move under the rectangular tube and a click is heard (fig. 13). If you have cross members with a flange larger than 60 mm [2.35"] then the Cargo Twister WIDE cannot be mounted and in its place the SPECIAL WIDE Bearing 40/25 needs to be mounted. The SPECIAL WIDE Bearing can be used with flanges up to a width of 120 mm [4.7"].

FIG. 13

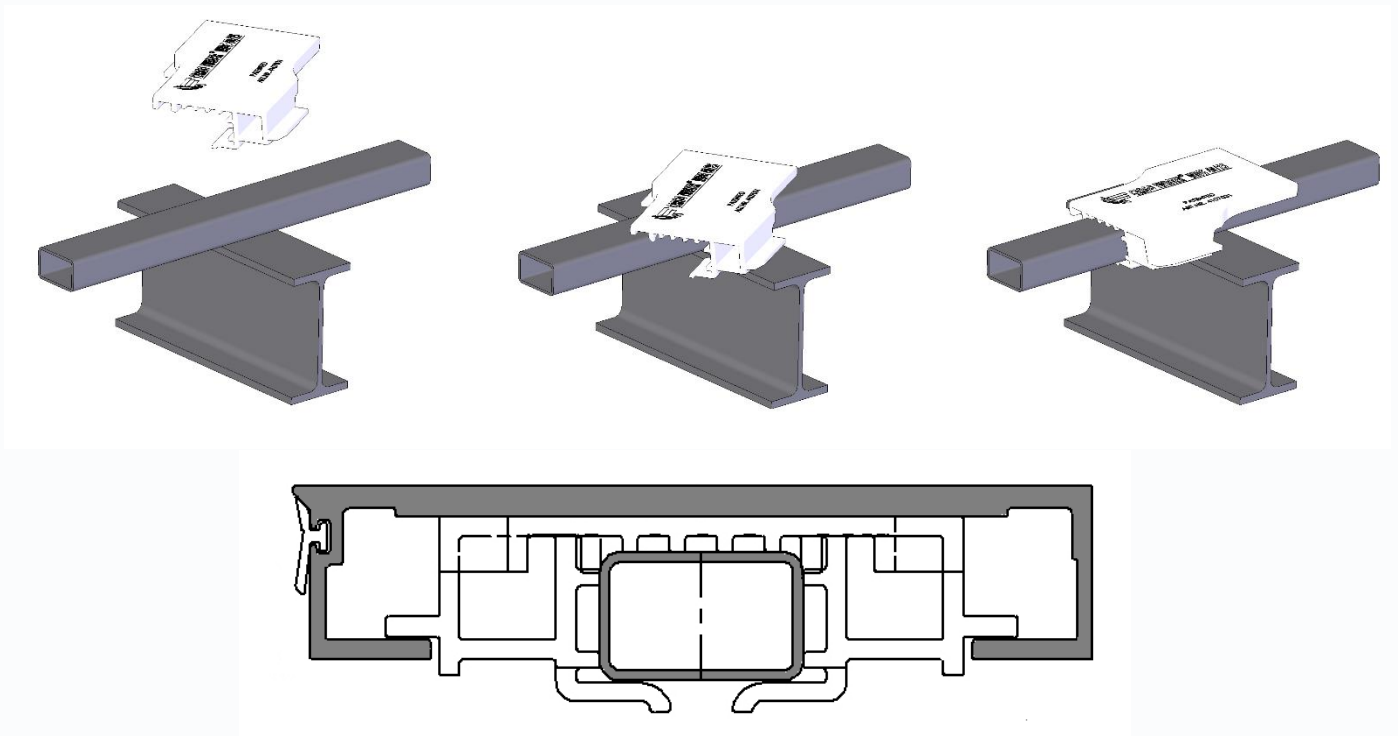

MOUNTING THE PLASTIC BEARING AND ANTI LIFTING SPECIAL WIDE BEARING 40/25

After the Cargo Twisters WIDE have been mounted the spaces in between can be filled with the SPECIAL WIDE bearing 40/25. This bearing is meant for cross members wider that 60 mm [2.35"] but smaller than 120 mm [4.7"].

The mounting of the unique and patented SPECIAL WIDE Bearing 40/25 (fig. 15) is simple and can be done without tools and only using one hand. You place a SPECIAL WIDE bearing 40/25 (parts no. [4107034](#)) over the rectangular tube and push it down. Because of the shape of the bearing, it will remain at its place.

The very last opening at the doors of the trailer must be equipped with 1 row of anti lifting. You also use the SPECIAL WIDE bearing 40/25 for this, the anti lifting effect of the profiles is achieved by mounting this bearing the other way around (fig. 14).

FIG. 14

SPECIAL WIDE Bearing 40/25
Used as bearing

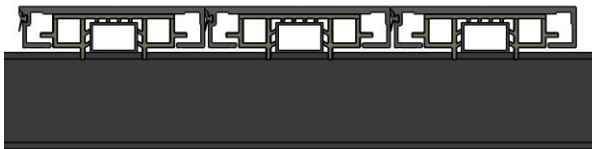

SPECIAL WIDE Bearing 40/25
Used as anti lifting

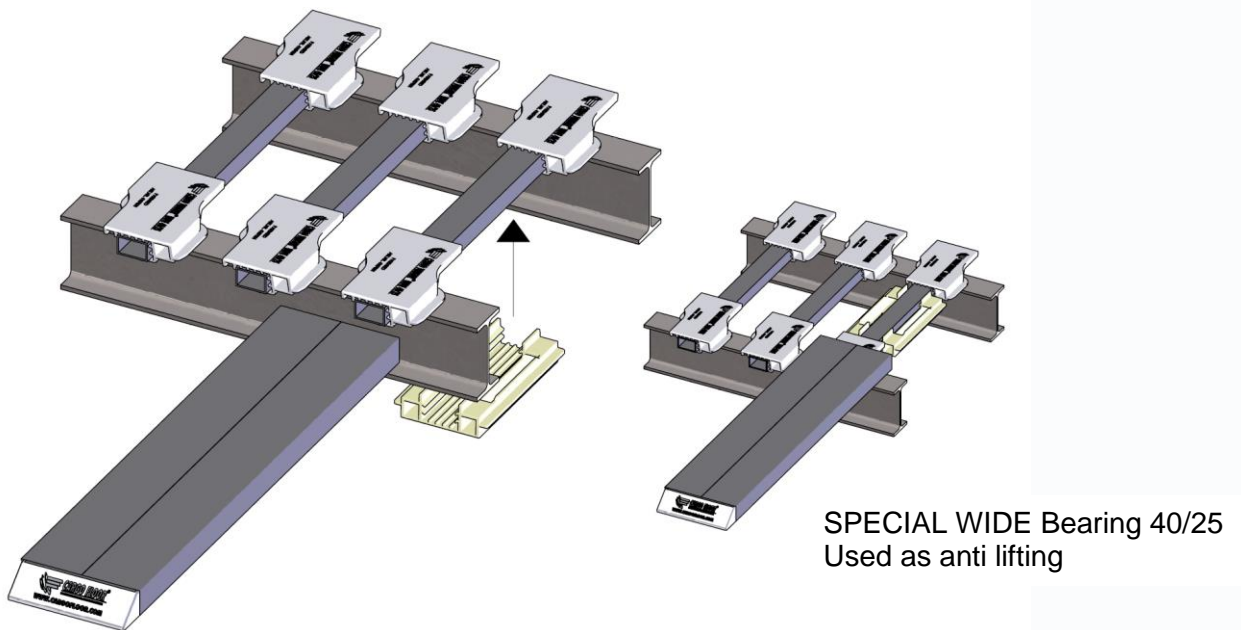
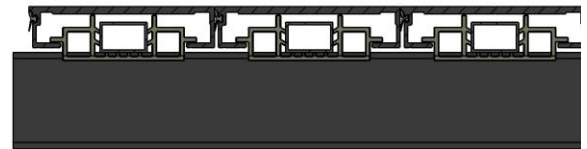

SPECIAL WIDE Bearing 40/25
Used as anti lifting

FIG. 15



CUTTING THE FLOOR PROFILES TO SIZE

Before you start: make sure that all profiles are facing the same direction and are facing the same way when put into the vehicle. This will prevent errors when measuring.

The aluminium floor profiles can be cut to size according to the table (see figure 16) after the plastic bearing have been mounted.

Pay attention to the fact that the floor profiles must be shorter than the inner measurement of the construction, and take into account whether the door is inside or outside the tailgate.

At the rear side a space of 40 mm [1.6"] needs to be adhered for the length of the endcap.

A space of 20 mm [1"] should be adhered to at the front and the rear of the construction.

FIG. 16

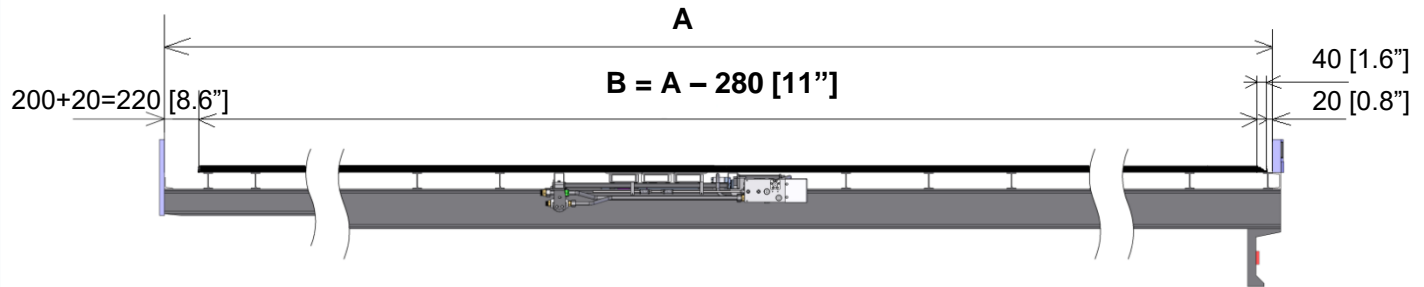

ROUND OFF THE PROFILES

After cutting the floor profiles to length they need to be rounded-off (beveled) at the front according to figure 17, so as to ensure a smooth guiding of the floor profile while sliding in, and to prevent damage to the plastic bearing.

To aid mounting, the rounded-off (beveled) side needs to lie in the mounting direction of the vehicle

For the next step let the profiles remain with the bottom up (for the holes).

FIG. 17

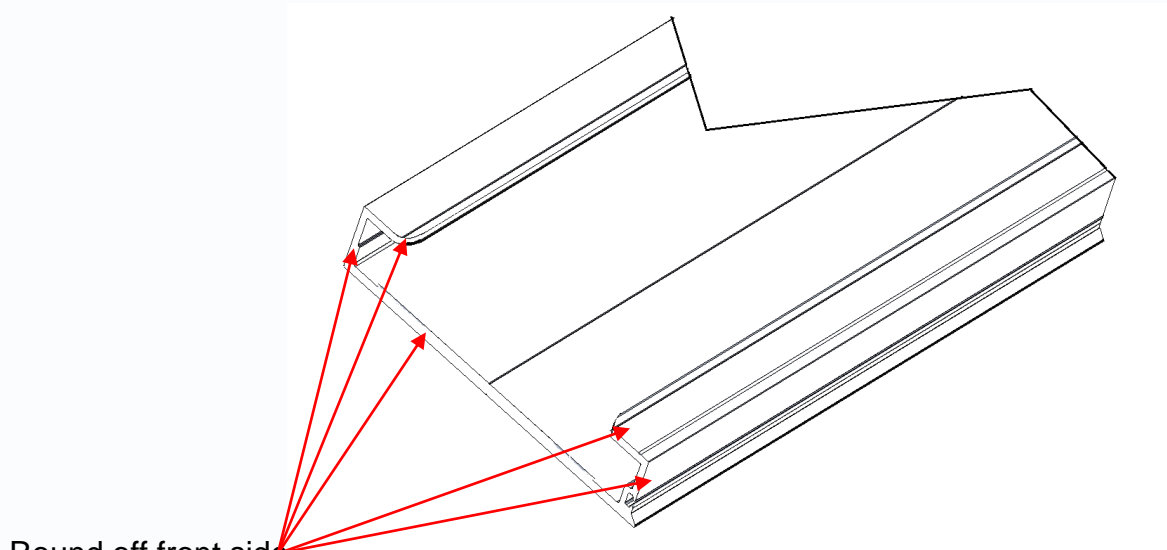

Round off front side
Both sides

DETERMINE THE POSITION OF THE HOLES IN THE PROFILES

First you need to determine the position of the holes in the profiles, see fig. 19.

Check if the cylinders are fully retracted. You check this as follows: the ends of the piston rods may not protrude out of the guide block for cylinderbar more than 5-10 mm. [0.20-0.39"].

The position of the first hole is determined by taking the measurement from the inside of the door side to the first hole in the U-profile moving crossmember of the third group. From this measurement you deduct 60 mm [2.4"] and with this you have determined measurement A.

Put a mark on the bottom side of the 5 profiles of the 3rd group at the spot of this first hole.

With the XHDI and HD profile take into account that on the left or right side a double seal (=DS) profile needs to be mounted. When marking the holes of the group that will have the double seal profile this group needs to have 1 less standard profile. (Meaning: the 15 profiles are divided up in 1 group of 4+1 (DS) profiles and 2 groups of 5 profiles.)

The 5 profiles of group 3 will have the hole pattern on measurement A.

The 5 profiles of group 2 will have the hole pattern on measurement A + 195 mm [7.7"].

The 5 profiles of group 1 will have the hole pattern on measurement A + 390 mm [15.4"].

FIG 19

Cylinders fully retracted

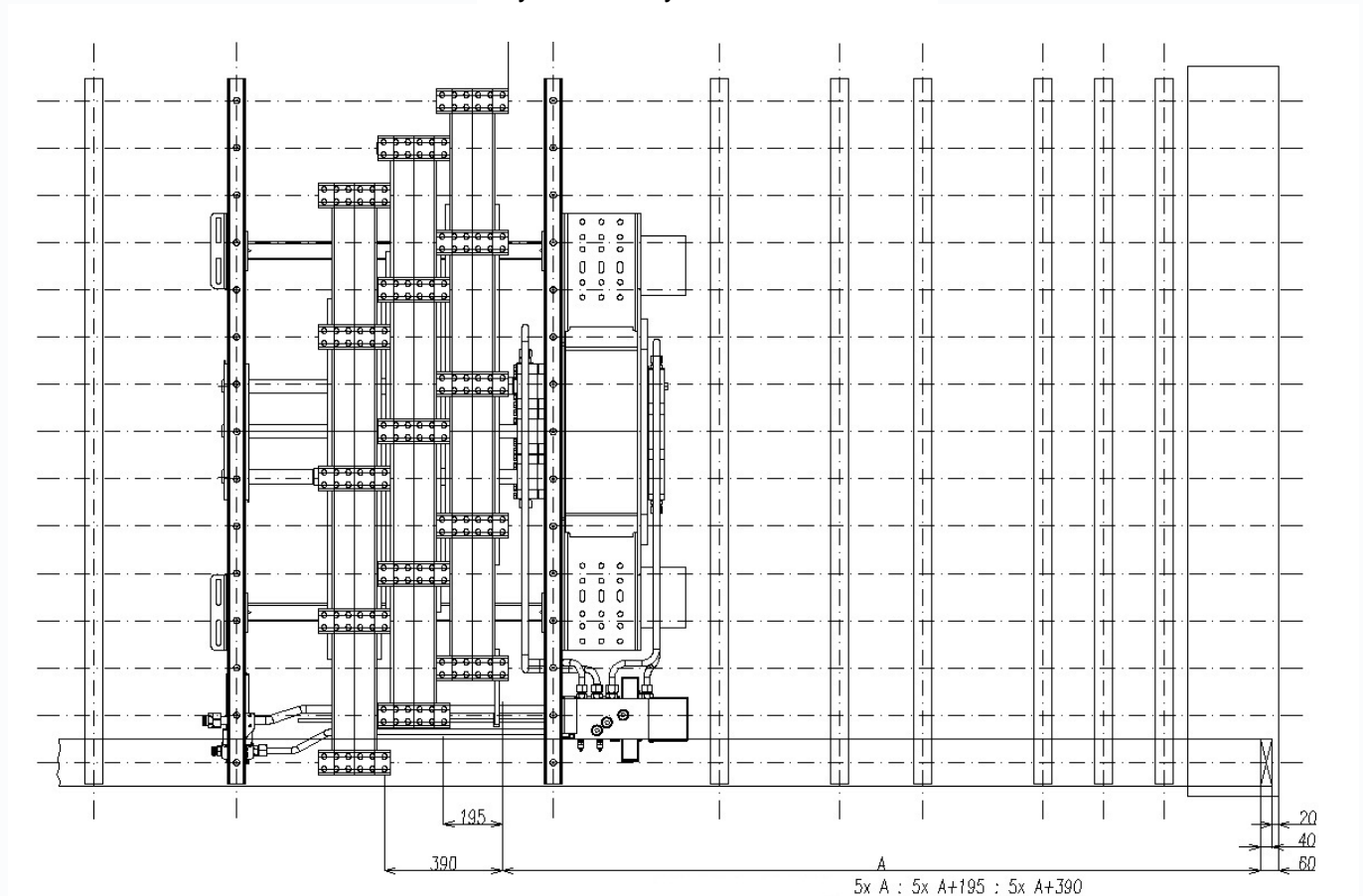

DRILLING THE HOLES IN THE FLOOR PROFILES

Using the 8xM12 screws

If the system is a standard CF500 SLC 15/156,8 version you use 8 screws per U-profile. The 4 holes on the sides are then used.

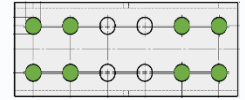

Using the 12xM12 screws

If the system is a Power Speed or is used in a stationary application 12 screws need to be used.

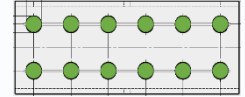

- Place all of the floor profiles with the sealing grooves in the same direction before you start drilling. Pay special attention to, when present, that the double seal profiles is at the extreme left or right. This agrees with the pattern of holes for the first or last moving cross member
- Then drill according to figure 19 the necessary number of floor profiles per moving cross members using the Cargo Floor drill jig, part no. 9111011.
- Predrill 8/12 holes of $\varnothing 4.5$ mm [$\varnothing 0.18$ "] with the aid of the drill jig on the inside of the floor profile . Then drill out the holes, from the same direction, to $\varnothing 12.5$ mm [$\varnothing 0.5$ "]. (fig. 21 A)
- Next the holes need to be countersunk from the top side using a good countersink bit according to the specification G136 HSS DIN 335 C, code 13628.0 (figure 21 B) Make sure that the hole is countersunk to the right depth; the screw head must not stick out above or under the floor profile. See figure 21 C.

FIG. 20

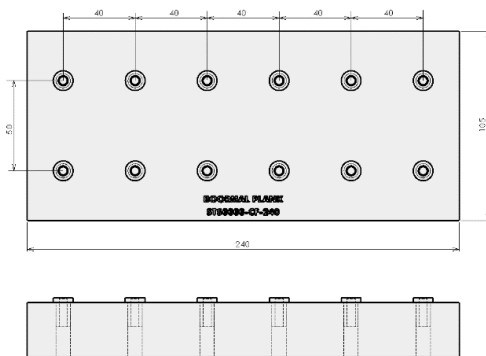

FIG. 21 A

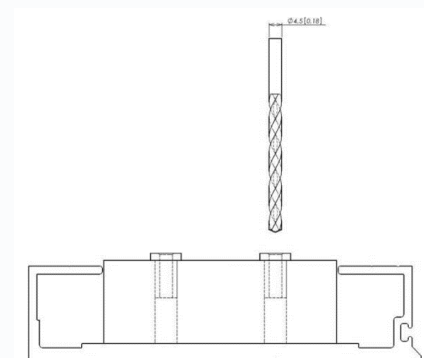

FIG. 21 B

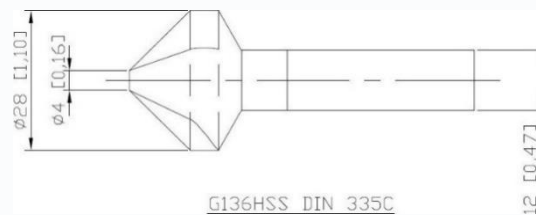

FIG. 21 C

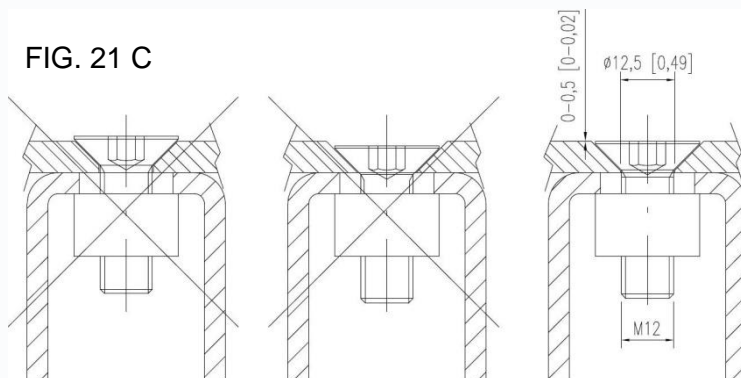
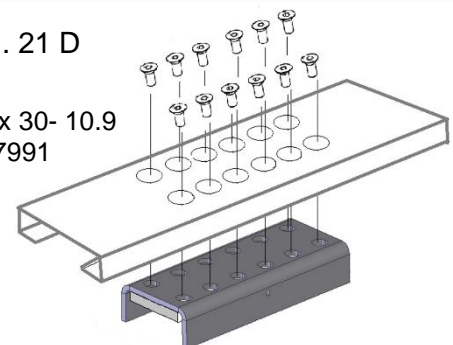

FIG. 21 D

M12 x 30- 10.9
DIN 7991



PREPARING THE FLOOR PROFILES AND MOUNT THE FLOOR SEAL

Step 1: Position the floor profiles side by side on some trestles, fig. 1.1. and weld all the aluminum endcaps, fig. 1.2 (alternatively, you can rivet the endcaps with steel rivets, see chapter “mounting the endcaps”).

FIG. 1.1

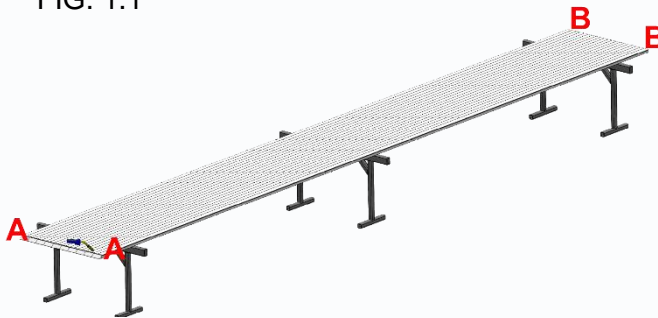
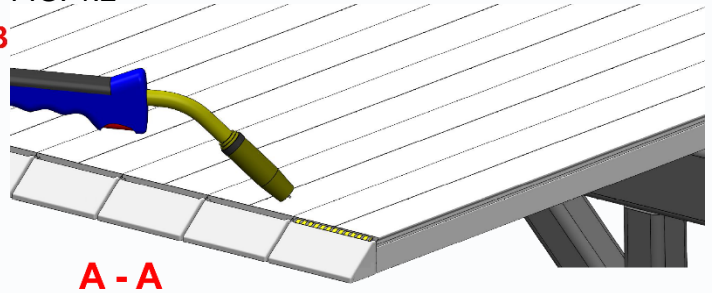

FIG. 1.2



Step 2: Only when you mount the profiles in the trailer by sliding them in horizontally from the rear, we recommend you to round off the front edges of the profile, fig. 2. When you mount the profiles vertically from above you can skip this step.

Only the red spots need to be rounded

FIG. 2

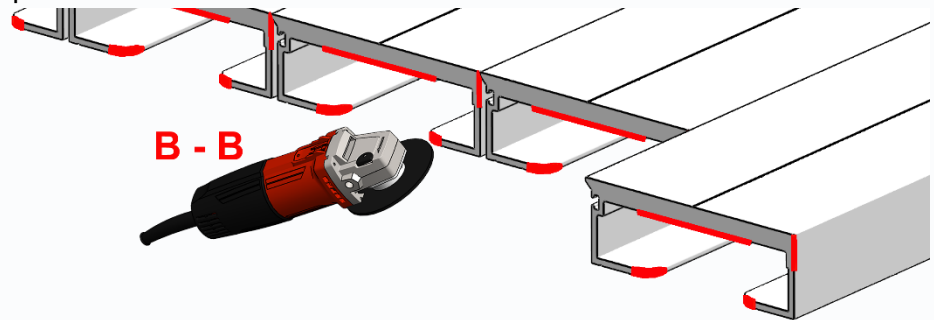

Step 3: Drill the holes in the floor profiles according to chapter “drilling the holes in the floor profiles”.

Step 4: Position the floor profiles vertically sideways – with the grooves positioned upwards - on the trestles, fig 4.1, check if the grooves are clean. Then check position of the seal, fig. 4.2, make sure it's the right way up! Then make a hand handle (fig. 4.3) in the seal by making a simple cut in the rear T of the seal.

FIG. 4.1

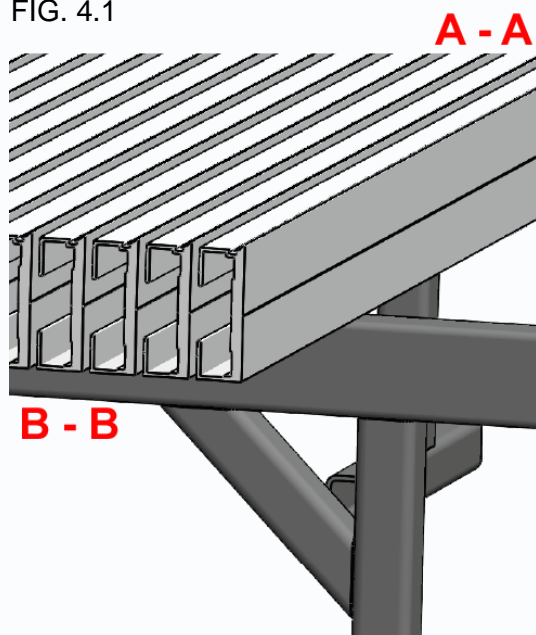

FIG. 4.2

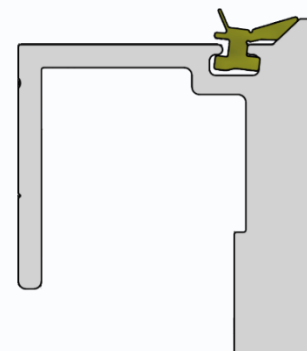
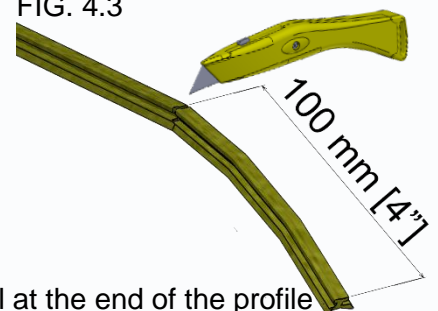
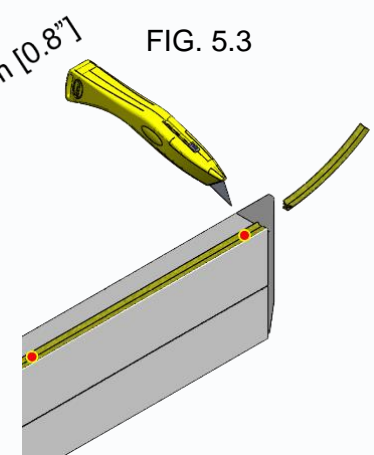
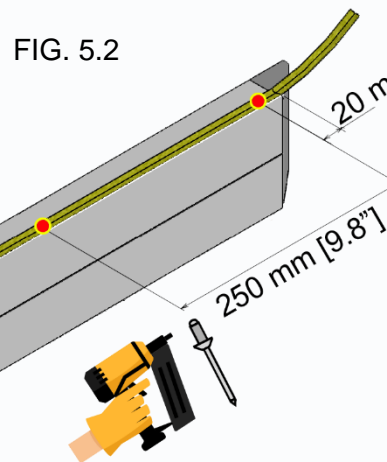
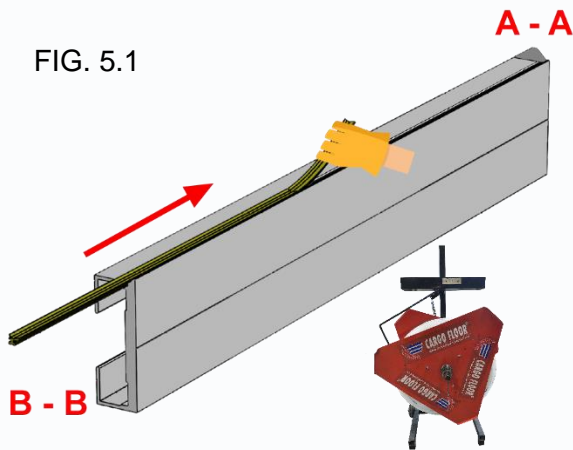

FIG. 4.3



Step 5: Now pull in the seal towards the endcaps (fig. 5.1). Fixate the seal at the end of the profile against the endcap with a nailgun or rivet (2 pcs, fig 5.2). Afterwards cut the handle off (fig 5.3).



Attention!

It might be handy to pull in all the seals in the floor profiles first before fixating them. After this is done you can fixate them in one go.

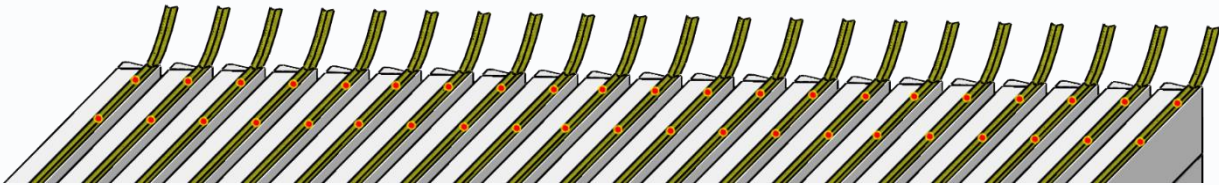

Step 6: Pull the seal to the right tension, fig 6.1, by stretching it and then push the seal down to block it, next fix the seal with a nailgun or rivet (2 pcs). See figure 6.2.

FIG. 6.1

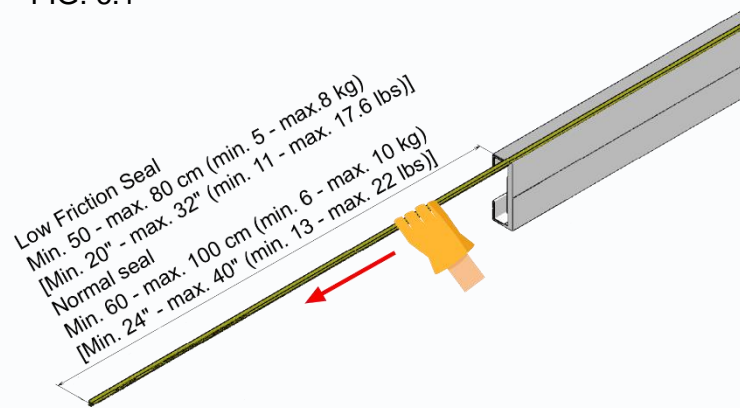
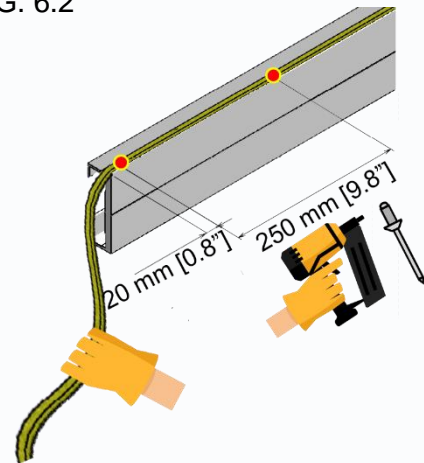



FIG. 6.2



Important remark!

 Low friction seal = min. 500 mm [20"] to max 800 mm [32"] or 5 to 8 Kg [11 to 17.6 lbs].
Normal seal = min. 600 mm [24"] to max 1000 mm [40"] or 6 to 10 Kg [13 to 22 lbs].

Step 7: Cut the seal and the profiles are ready for mounting!

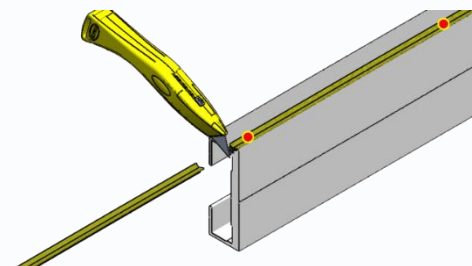

MOUNTING THE ENDCAPS

The endcap can now be mounted. The endcap can be hammered into the profile with a plastic hammer. Fasten the block by welding it according to fig. 23.

FIG. 23

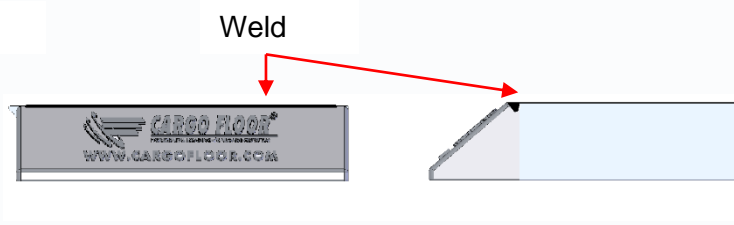

SECURING THE FLOOR PROFILES TO THE DRIVE UNIT

After the floor profiles have been cut to size, rounded-off, drilled, and had the seals and endcaps mounted, they can be slid over the plastic bearing at the required position (matching up the hole pattern with respect to the moving crossmember). You need to carefully guide the floor profiles during the mounting procedure. Next, the provided galvanized M12 bolts (Allen No. 8) with countersunk head should be fitted with Loctite (Loctite 243 cat.o. 23286 screw thread locker), after which they can be mounted. Mount 8/12 bolts per profile. The bolts need to be tightened firmly (fig. 21C), a torque of 100 – 140 Nm [72 – 105 lbf.ft] should be used to tighten the bolts. One person can do this from above.

SECURING THE STATIONARY SIDE PROFILES

The side profiles always need to be mounted 2 mm lower than the moving floor profiles (see figure 24 A). The stationary side profiles need to be pushed firmly against the moving floor profiles before they are secured. Next the stationary side profiles need to be secured every 1.500 to 2.000 mm [5' to 6,6'] with mono-bolts, with countersunk heads, which are not permitted to stick out above the side profile (see figure 24 A). The opening between the sidewall and the stationary profile needs to be filled with a flexible sealant.

Alternatively you can mount it with a bolt connection or make small welds.

It is better not to weld the stationary side profiles completely to the sidewalls, since at a later stage side profile may need to be retensioned, and to do this the side profiles need to be loosened.

Cargo Floor has standard side profiles (fig. 24 B) available in 6 [0.23"] and 10 mm [0.39"] thickness, which can simply be mounted.

These can also be used in combination with the XHDI or HD profile (for the Sealless profile, an extra sealless profile will have to be supplied to make the connection to the walls).

FIG 24

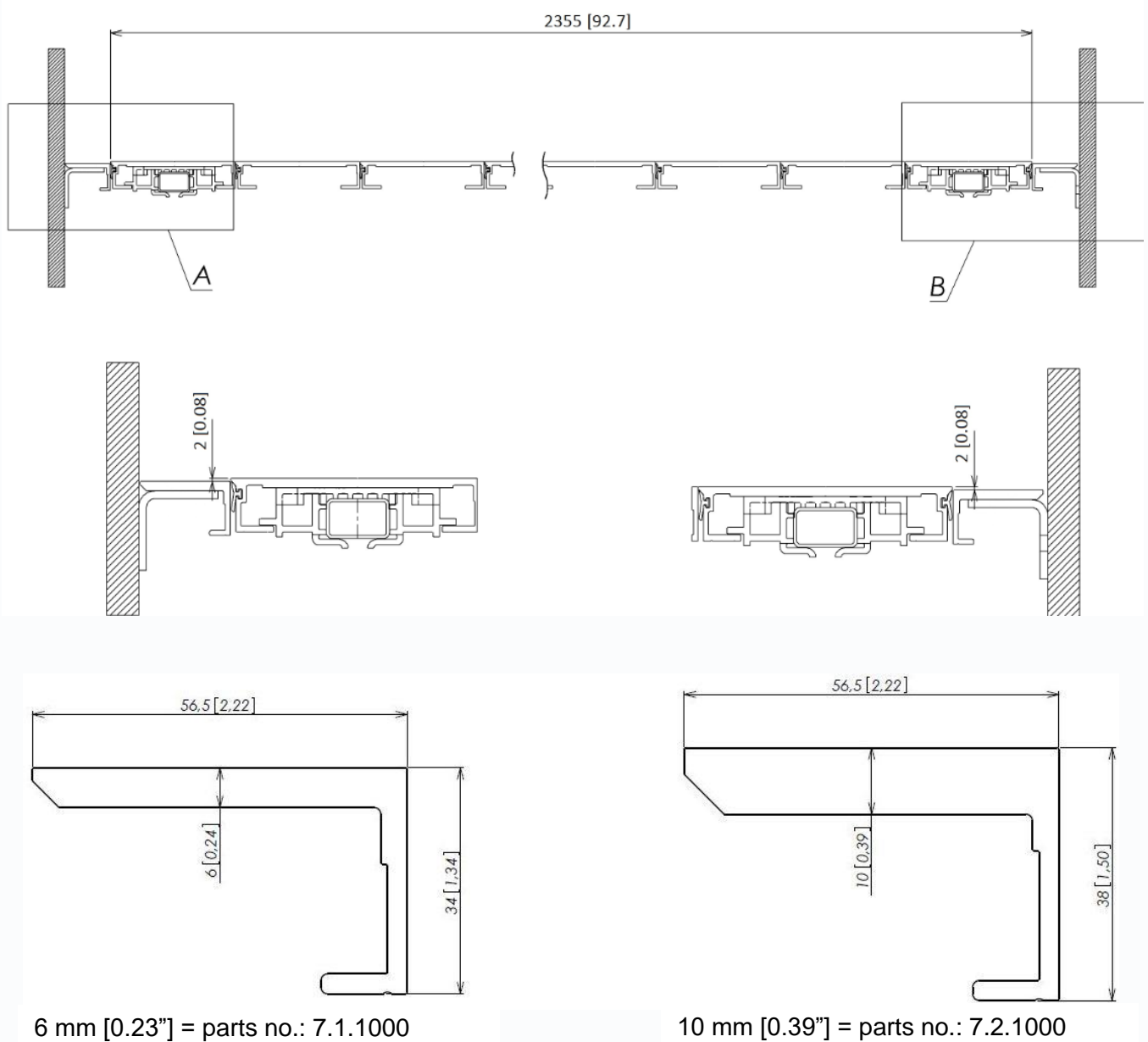

SEALING THE FRONT SIDE OF THE FLOOR

A reinforced flat plate (length minimum 250 mm [10"]), width dependent upon the inside of the trailer, mounted on the front wall of the trailer can be used to cover the opening created by the operational stroke of the system. On the underside of the front part of the cover plate the supplied plastic strip (2500x75x5 mm [98"x3"x0.2"]) needs to be mounted in order to prevent wear and attain a good sealing.

Different strips are available for the different kinds of profiles:

- XHDI : parts no. 4103050 mounting underneath
- HD : parts no. 4103039 mounting underneath, 4103046 front mounting
- Sealles : parts no. 4103041 mounting underneath, 4103048 front mounting
- Protected seal : parts no. 4103043 mounting underneath, 4103049 front mounting

Ensure here that the fasteners countersunk in the plastic strip are mounted so that they do not come in contact with the floor.

A heavily reinforced cover plate needs to be mounted at an angle of 45° for trucks that are used for loading / compressing, see figure 25.

The construction needs to be very sturdy, so that it will not buckle or rise up.

FIG. 25

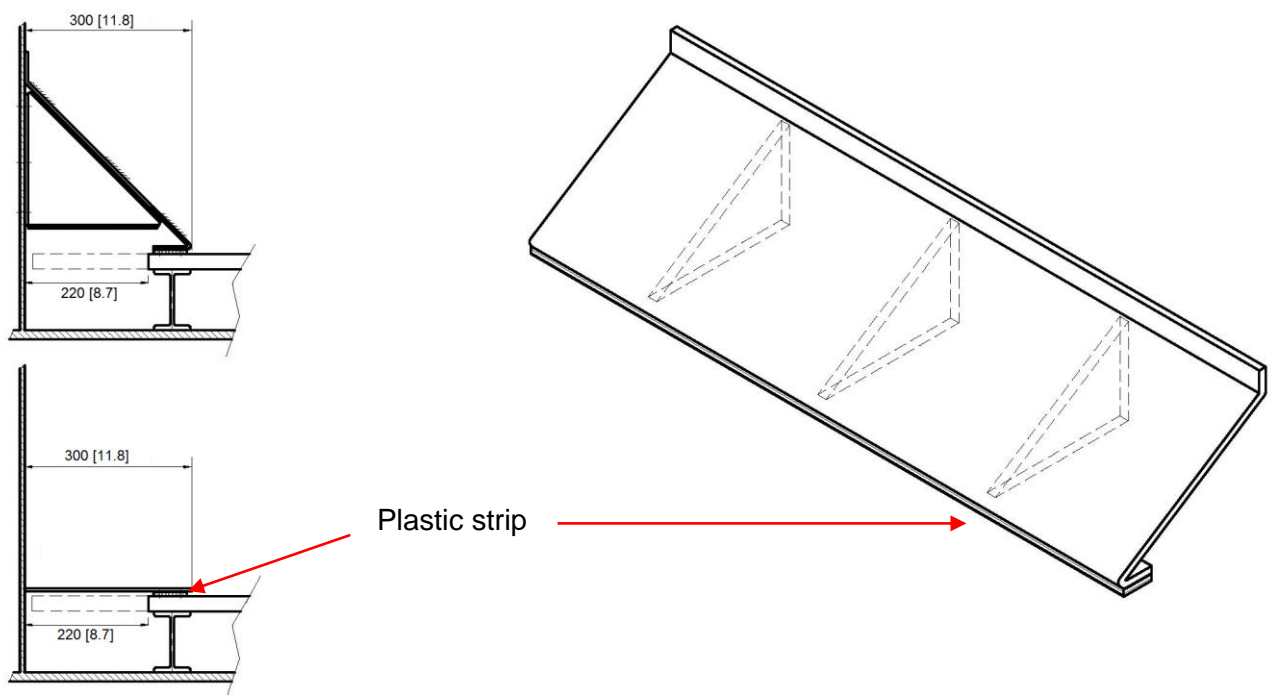

MOUNTING THE CONTROL BOX AND THE ELECTRICS

The control box can simply be mounted, without drilling holes, to your own mounting construction or on the mounting bracket that can be supplied as an option. This mounting bracket can, depending on the shape of the cross members, be mounted without drilling holes with the supplied clamping plates. The mounting bracket has three heights for mounting the control box. Also the, optional, wireless remote control RX/TX can simply be mounted into the control box, with the E-control as well as the B-control.

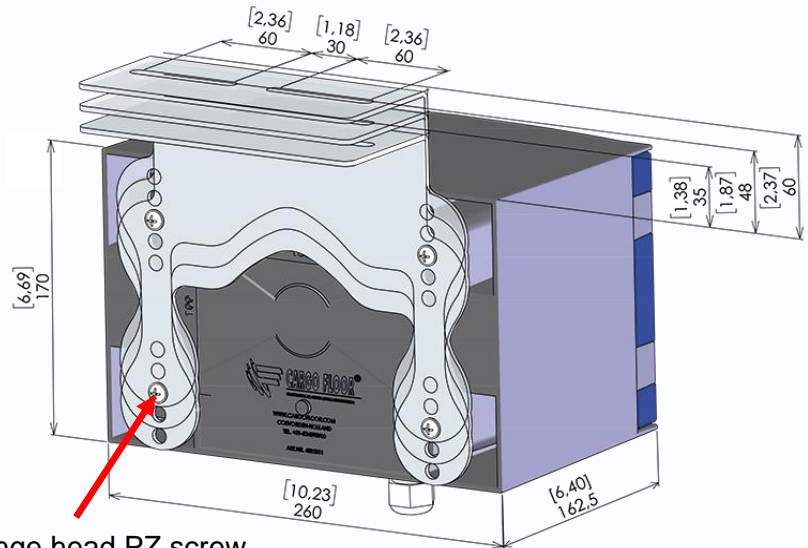
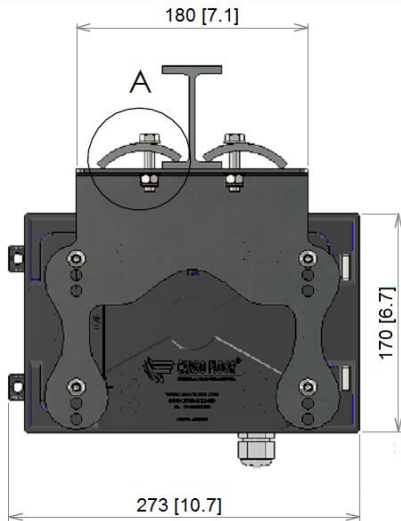

Flange head PZ screw for plastic, 6x20 mm

E-control

With the E-control the controlbox CF7 is provided with 3 electrical cables:

- A two-core connection cable for the power supply. The brown cable needs to be connected to the 24V+ and the bleu cable to the 24V-.
- A two-core cable with premounted black plug Deutsch for solenoid GS02 on/off;
- A two-core cable with premounted grey plug Deutsch for solenoid G02 unloading/loading;



G02 unloading/loading plug grey

GS02 on/off plug black

B-control

With the B-control the control box CF3 is provided with 3 electrical cables:

- A two-core connection cable for the power supply. The brown cable needs to be connected to the 24V+ and the bleu cable to the 24V-.
- A two-core cable with premounted black plug Deutsch for solenoid GS02 on/off;
- A two-core cable with premounted grey plug Deutsch G02 equipped with a watertight end cap and sticker "do not cut".



It is important that the watertight plugged cable with the grey plug is brought to the control valve, but not can nor needs to be connected. This cable and plug need to be fastened somewhere near the control valve. The mounted watertight plug may not be removed.

THE MOVING HEADBOARD

The moving headboard can be made from sidewall profiles reinforced by an edge profile. It is also possible to use a frame with a tarpaulin as a moving headboard. It is the best to hang the headboard on two Cargo Rollers, Heavy Duty, 6 wheels with bi-directional cleaning device in the rails (part no. [5165003](#)), see figure 31A, mounted on the top edge of the trailer. Many aluminium top edges have this rail already integrated.

Mount the rails at the same width as the width of the trailer. The moving headboard needs to be fastened to the Cargo Roller with at least 3 chains links and make sure the hanging point of the headboard is directly beneath the roller so that the headboard can move freely and the Cargo Rollers won't jam. Let the moving headboard run free on both sides of the side walls, about 25-30 mm [1"-1.25"]. Brushes or rubber flaps can be mounted between the headboard and the sidewalls to avoid leakage and to keep the sidewalls clean. The sidewalls of the trailer need to be smooth so the headboard cannot get stuck on something.

FIG. 31 A

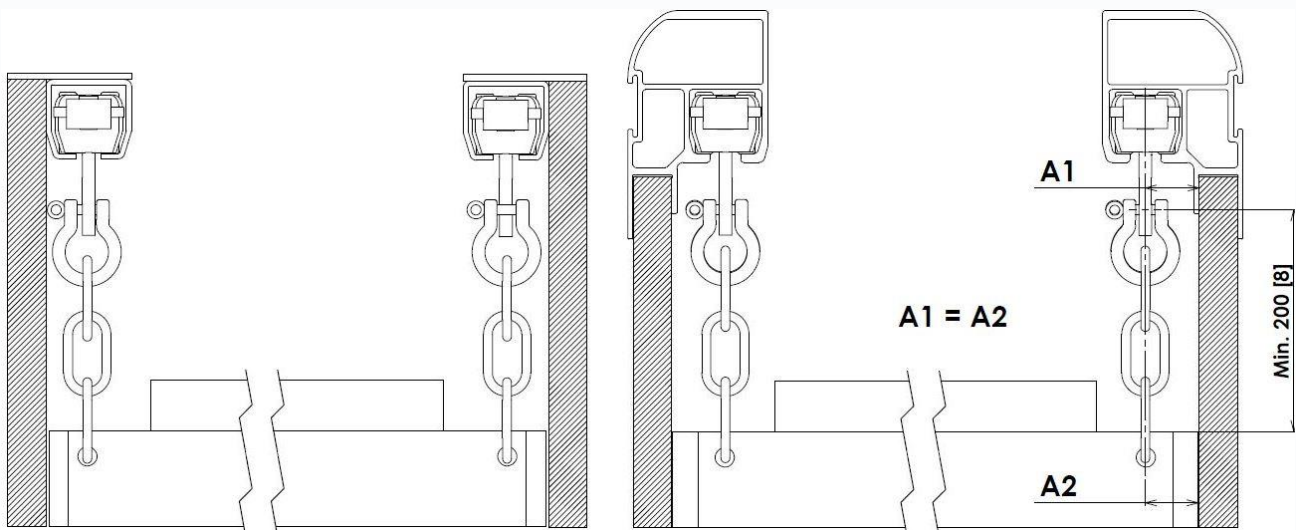
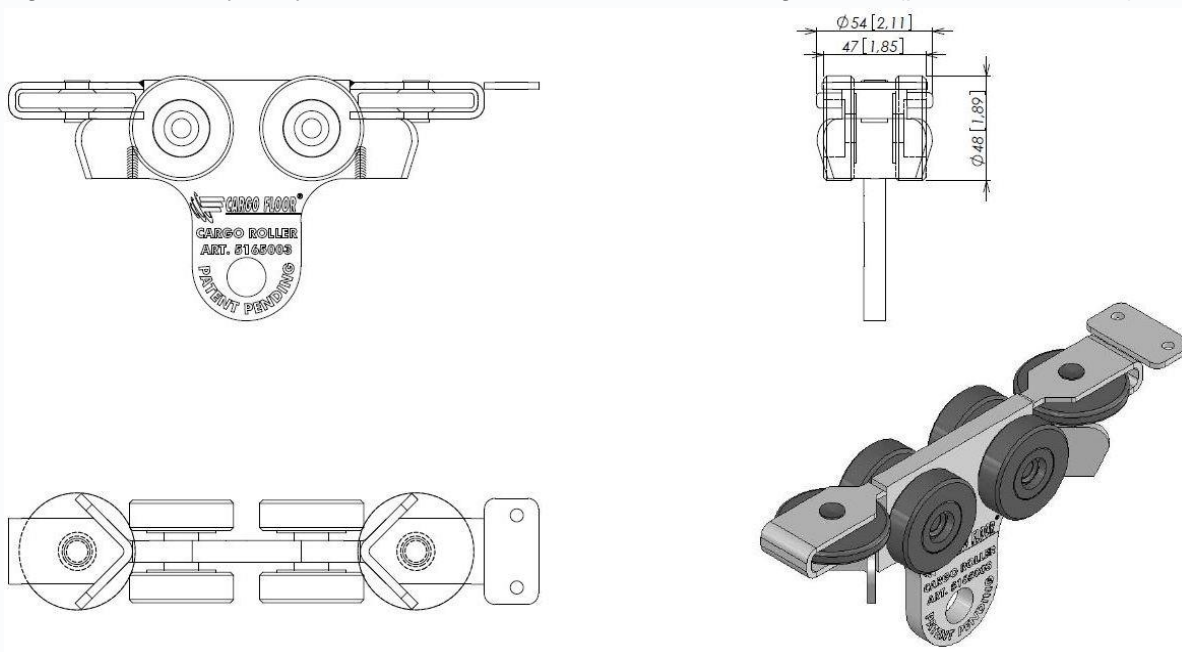

FIG. 31 B

Cargo Roller, Heavy Duty, 6 wheels with bi-directional cleaning device (part no. [5165003](#))



THE MOVING HEADBOARD TARPAULIN

In order to allow the headboard to move with the load, a tarpaulin is fastened to the underside of the moving headboard, see figure 32. A section of this tarpaulin (about 1.250 mm [4']') needs to lie on the floor. This section of the tarpaulin needs to be fitted with one or more pine (wood) planks. The planks are in loops of the headboard tarpaulin of the tarpaulin is clamped between these planks. The fastening bolts/screws need to be well countersunk to ensure that they do not come in contact with the moving floor.

⚠ Attention! These planks are about 20 mm. [0.79"] shorter than the smallest internal width of the loading space of the container.

FIG. 32

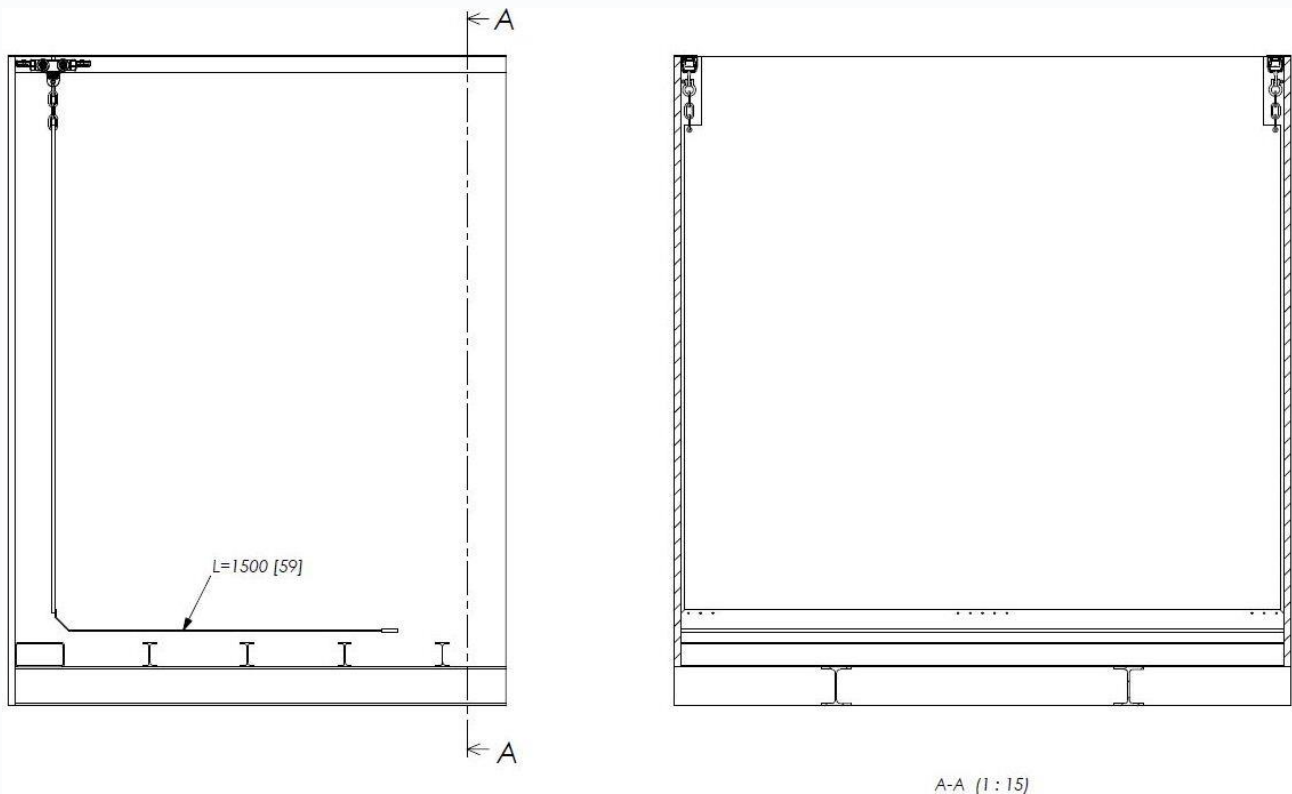

ADJUSTMENT OF THE THREADED ROD OF THE CONTROL VALVE

Front side trailer

Rear side trailer

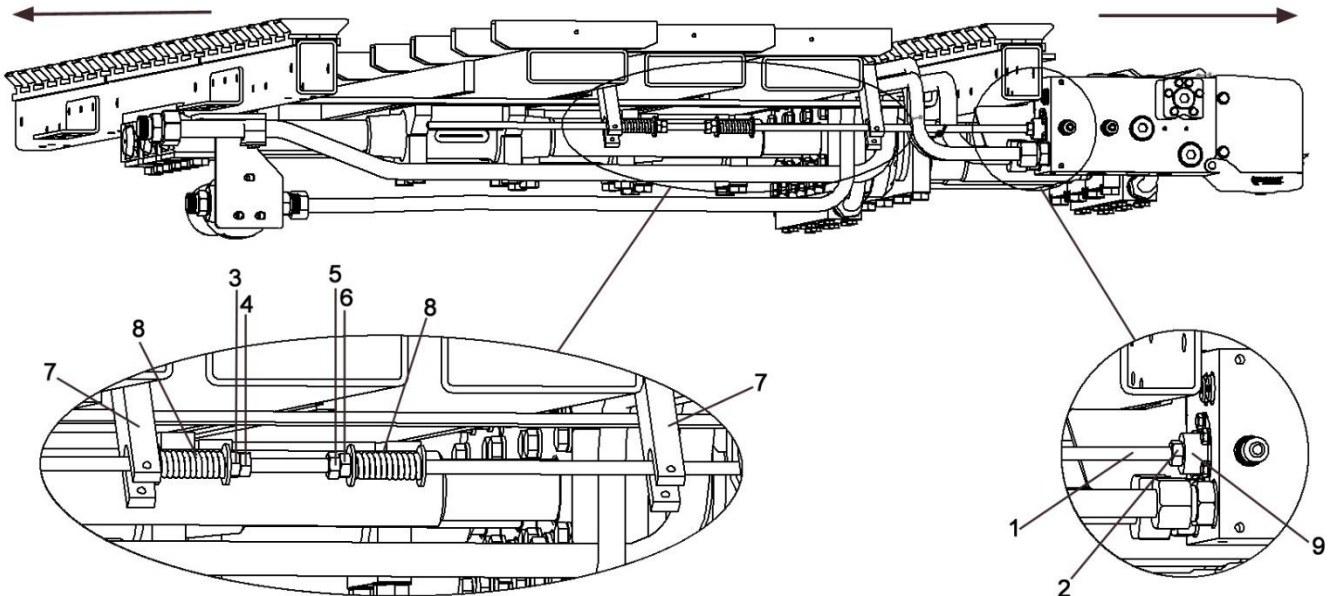

All Cargo Floor systems have the threaded rod set and are fully tested. You therefore do not need to adjust the threaded rod, but in certain circumstances (f.e. certain repairs) it may be necessary to check or adjust the setting of the threaded rod. If switching spontaneously doesn't go normally anymore, then please make a good assessment first why this has happened.

Attention:

The pump and electrical installation must always be switched-off when working on the system; in addition, the hoses and/or pipelines between the pump and the Cargo Floor should also be disconnected.

If not the risk of entrapment arises!!!

Necessary tools:

- 2x spanner 17;
- High viscosity oil;
- Copper grease;
- Steel brush.

Check that the threaded rod (1) is fastened securely to the switching valve, with pressing and pulling the stroke is exactly 12 mm. [0.5"].

If not, then screw the threaded rod (1) as far as possible into the plunger and secure this with the contra nut (2) (spanner size 17). Loosen nuts (3 and 4, spanner size 17) and move these about 3 cm [1.25"] in the direction of the rear of the trailer.

Now switch the pump on while you are at a safe distance. The system will start to move and stops automatically at the point where the command lip (7) no longer operates the switching valve, because the spring (8) is no longer pushed. Switch off the pump immediately.

Now push the threaded rod (1) in the direction of the rear of the trailer until the spacer ring (9) touches the control valve.

Tighten nuts (3 and 4) so far in the direction of the front side of the trailer that the spring is fully pushed in, and secure them by tightening them against one another. Repeat this procedure for the other side (nuts 5 and 6) by doing everything in opposite directions.

N.B. It is worthwhile spreading some copper grease on the threaded rod (1).

TECHNICAL SPECIFICATIONS

- System operation** : fully hydraulic, with three double-action cylinders
System control : fully hydraulic mechanical
Controls : fully automatic loading – stop – unloading, optional A/B-control

	CF500 SLC	
Bore (mm)	100	[4"]
Piston rod diameter (mm)	45	[1.77"]
Stroke (mm)	200	[8"]
Cylinder volume (ltr)	2,82	[0.75 us gal]
Oil volume per cycle (ltr)	8,46	[2.25 us gal]
Over pressure valve threshold, max. operational pressure (bar)	225	[3,300 psi]
Strokes per minute with advised pump capacity	13	
Speed (mtr./min.) with advised pump capacity	2,6	[8.5 ft./min]
Advised pump capacity:		
Flow (ltr./min.)	110	[29 gpm]
Pressure (bar)	250	[3,625 psi]
Max. pump capacity:		
Flow (ltr./min.)	130	[34.5 gpm]
Pressure (bar)	250	[3,625 psi]
Speed at maximum pump capacity (mtr./min.)	3,1	[10 ft./min]

- Control valves** : 24V DC
Throughput variation : completely variable speed by use of oil flow determined by the revs of the motor or by various pumps. Pay attention to the diameter of the choke, see chapter [connecting the hydraulics](#).
Drive : use of the PTO/pump on the truck; an electro-hydraulic aggregate or a hydraulic aggregate with an external combustion engine.
Filter : pressure filter type: high-pressure 10 micron
Pressure piping : Ø 20 x 2 feed through 16 mm
Return piping : Ø 25 x 2,5 feed through 20 mm
Oil ISO VG 32 : Shell Tellus T32 or BP HL2-32 or ESSO Univis 32 (or equivalent).
 Only use biological oil after agreement by Cargo Floor B.V.
Biological oil : a biological oil of the type synthetic ester (HEES) can be used as standard with the CF500 SLC BULKMOVER system. We advise you not to use other types of biological oil.
Oil temperature : max. 100 °C [212 °F]
Floor Profiles : aluminium
 Profile length negotiable
 Thickness 6 mm, 10 mm, HD 8 mm [0.24", 0.39", HD 0.31"]
 Width 156,8 mm [6.2"]
 Moving floor width standard 2.355 mm [92.7"] for an inner width of 2.500 mm [98.4]
Quality : high quality alloy, weldable, very wear-proof and tensile
Bearing : the aluminium floor profiles are supported by wear-resistant plastic bearing Cargo Twister WIDE 40/25 of Special WIDE bearing 40/25.
Guide bearing surface : the total bearing surface of the Cargo Twister WIDE 40/25 is 144 cm² [22.32 sq.inch]. The total number of guides, which can be varied as required, determines the total guide surface area.
Under floor : steel as well as aluminium. For the plastic bearing use the rectangular tubes 40x25x2 [1.6"x1'x0.08"] or aluminium u-profile.

MAINTENANCE INSTRUCTIONS

When works require turning on the floor you should take care of that the floor can be shut down immediately at any time. Places where clamping/clasping of body parts is possible may not be approached when the system is moving.

Check for the end user / owner after receipt of the new Cargo Floor trailer

Check a couple of days after receipt of the new trailer and / or after 10 loads / unloads and after one month the connection between the aluminium floor profiles and the Cargo Floor system. You do this by placing your finger half on the screw and half on the floor profile when the floor is operating.

Important: if you feel a difference in movement between the screw and the floor profile it means the floor profile is not fastened enough. The screw connection of the whole profile group this concerns needs to be renewed with new screws in accordance to the fastenings guidelines mentioned in the assembly instructions (see www.cargofloor.com, downloads). Also the countersunk hole needs to be cleaned properly. Do not check the screw connections with the help of an Allen key and do not simply just tighten the screws, the Loctite connection will be broken.

Specifications of the screws: Screw M12x30 Dacromet 10.9. (with locking glue), article number 502112030.1.

The torque is 100 - 140 Nm [72-105 lbf.ft.]

Regular checks and preventive maintenance

To ensure that your Cargo Floor system operates reliably and has a long life, it is important that you regularly perform careful checks on the following aspects:

- Replace the filter element every year, or more often if needed. By removing the filter lid/chamber you can check the filter element,
- Change the oil every 2 years, or more frequently if required;
- The level of oil in the tank. See for oil levels and the oil specifications the technical specifications.
- Floor profiles: are they still fixed, replace screws if necessary!
- Check the guide blocks for the 3 piston rods for wear
- Check the coupling nuts and couplings of all hydraulic components, and adjust if necessary!
- Oil tank: by taking the lid off the tank, you can remove any remains (condensation, dirt etc.) from the bottom.
- Check the seal between the two fixated floor profiles and the moving profiles. If a margin exists in-between, then adjust the fixated floor profiles, in order for the sealing to be optimal and leakage via the side walls is prevented
- Clean the floor.

This is all necessary to avoid internal wear (of the pump/cylinders etc., for example).

New filter parts are available at your system builder.

We want to emphasize that the minimal costs of replacing dirty parts or oil do not match the costs and discomfort that can arise.

IMPORTANT INSTRUCTIONS

- Avoid letting dirt and water get into the hydraulic system when disconnecting the connectors or when topping up/cleaning the oil tank.
- Adjust the work speed when, for example, heavy massive products are being loaded or unloaded with which the system needs the maximum power ([see chapter technical specifications](#)), so as to avoid overloading.
- It is not permitted to exceed the maximum operational pressure ([see chapter technical specifications](#)).
- Avoid loading and unloading sharp objects without a protective roll-up cover mechanism. This causes unnecessary wear of the seal/floor profiles. If you would like to transport such materials safely, we advise you to use a protective roll-up cover mechanism.
- Never exceed the maximum number of strokes per minute when using the full stroke ([see chapter technical specifications](#)). A greater number of strokes causes enormous forces in the system and chassis, and causes a lot of heat to be generated in the hydraulic system.
- When loading and unloading packed goods it is important that a good equal weight distribution is realized on the floor. If this is not the case there is the possibility that the goods will not move. When using pallets, if necessary, place a wooden plank (of about 300x18x2350 mm [12"x 0.75"x92.5"]) multiplex underneath.

TROUBLESHOOTING E-CONTROL

In the event of the failure of the Cargo Floor system to operate (in the correct manner) when used in accordance with the operating instructions carry out the following checks:

Malfunction system	Concerns part	Cause	Solution
1. Does not operate No oil flow control valve	PTO	Not switched on	Switch on PTO
	Quick coupling	Blockade	Check couplings / mount correctly
2. Does not operate There is oil flow control valve	Switch	Stop operated	De-activate stop
	Solenoid valve GS02 on/off	Interruption wiring Interruption in coil	Activate manual override GS02 temporarily and/or repair power supply
	Pressure control valve	Polluted	Clean / replace pressure control valve, attention: do not open the pressure control valve in parts
	Oil temperature switch	Interruption solenoid due to overheating	Let the oil cool down.
	Operation plunger in the middle position	Flow <60 l/m [16 US gpm] See chapter: choke	Increase pump rpm Install another pump Adjust choke
		Hoses connected reversed	Check filter first, then connect pressure and return correctly.
	Plunger moves with difficulty due to molten seal	Replace seals operation plunger	
3. Starts immediately after switching on the PTO	Switch CF7	Switch movement blocked in the on position	Remove blockade
	GS02 on/of	Manual override activated	De-activate manual override, put yellow security clip back in place
	Hoses connected reversed	Pressure and return hoses are swapped	Check filter first, then connect pressure and return correctly.
4. Individual movement is difficult and/or incorrect with a full trailer	Pressure control valve	Tipper valve	Turn tipper valve in correct position
		Pressure control valve pulling vehicle max. pressure to low	Measure max. pressure/ adjust pulling vehicle
		Return oil has restrictions	Measure pressure M2, remove restrictions
	Capacity of the system is insufficient.	Too much load	Unload part of load with crane
		Pollution between the profiles	Clean
	Frost	Thaw	
5. Individual movement is incorrect when unloading With a full and empty trailer	Valve in cylinder head 1 or 2	Pollution prevents a good closure	Remove pollution
		Broken valve spring	Replace spring
	Valve seat in cylinder head 1 or 2	Valve seat has loosened	*Replace / fasten valve seat
	Common rail cylinder rod side	Stop in the common rail has loosened	Fasten stop / replace common rail
Common rail mounted the wrong way around		Mount common rail correctly	

Malfunction system	Concerns part	Cause	Solution
6. Switching is difficult or goes not at all. 3 Cylinders are fully retracted or fully out.	a. Threaded rod	Adjustment incorrect	Adjust correctly, attention: determine cause. See: b. and c.
		Switching spring broken	Replace spring, attention: determine cause. See: b. and c..
	b. Switching plunger	Stroke > 12 mm. [0.5 inch] -> threaded rod loose, spacer loose	Screw in Threaded rod / bolt fully.
	c. Moving cross member	Slanting caused by loose profiles	*Replace screws and provide them with a thread locking product and check the rod bearing.
	d. Switching choke	Polluted	* Clean choke
7. Floor unloads when choosing loading and unloading	Solenoid valve G02 loading / unloading	Interruption wiring Interruption in coil	Activate manual override G02 temporarily and/or repair power supply
8. Floor loads when choosing loading and unloading	Solenoid valve G02 loading / unloading	Manual override G02 is activated	De-activate emergency control
9. Other malfunctions	Please contact your trailer builder or Cargo Floor B.V., keep the system number at hand.		

* Contact us for the right repair advice.

WARRANTY CONDITIONS

Warranty shall only be given with the prior consent of Cargo Floor B.V.! With warranty requests always fill in and send a warranty request form to Cargo Floor B.V. beforehand. You can fill in a request for warranty simply on our website: www.cargofloor.com.service.

The warranty conditions, as specified in the most recent “Metaalunie” conditions, filed with the registrar of the District Court of Rotterdam, are applicable in unabbreviated form. On request available.

A short extract of these conditions follows:

Pay special attention to, when present, that the double seal profiles is at the extreme left or right. This agrees with the pattern of holes for the first or last moving cross member

A warranty period of 12 months (starting directly after installation) applies for all Cargo Floor system materials supplied by us. In the case of malfunction and/or manufacturing faults we are only responsible for the costless supply of replacement parts, if:

The warranty period is for the first equipment owner only

The Cargo Floor system is installed by your trailer builder according to our installation procedures

Our maintenance and control procedures have been followed

In the case of a malfunction, the system builder, or Cargo Floor have been informed

The following components are not covered by the warranty:

- Malfunction of equipment, or caused by equipment, which was not supplied by Cargo Floor B.V.
- Malfunction caused by the use of dirty oil, or oil of the wrong type
- Malfunction caused by overheated oil, T. max. ≤ 100 °C [212 °F]
- Malfunction caused by overloading or injudicious use
- Malfunction caused by improper repair work, or repair work which is carried out by third parties
- Malfunction caused by corrosive materials
- Filter elements and components, which are subject to normal wear-and-tear and are not warranty items
- Defects in electrical components due to incorrect connection and/or incorrect voltage levels
- Consequential damages

The warranty is void if:

- The system is used for purposes, which have not been recommended Cargo Floor B.V.
- The wet kit is not as recommend in the Cargo Floor manuals
- The Cargo Floor system is not installed properly
- Load in excess of legal limit are moved as defined in Cargo Floor manuals and operating instructions.
- The Cargo Floor system has not constructed correctly by your trailer builder, insofar as this has a negative influence on the operation of the system.

Cargo Floor B.V. hereby warrants, only to the first owner of a new Cargo Floor unloader from the factory or selling distributor, that the Cargo Floor hydraulic parts and hydraulic components shall be warranted as free from defects in material and workmanship for a period of 12 months year to the first registered owner from the date of the sale.

This warranty does not cover normal wear and tear, maintenance, or heat damage. It is not to be construed as a service contract.

Note: Prevention of excessive heat in the hydraulic system is the single most important factor for long system life. Bad pumps, improper wet kits and hydraulic restrictions cause excessive heat and will damage the hydraulic system. Heat damage will void the warranty.

Definition of normal use and service:

Normal use and service means the loading and/or unloading of uniformly distributed, non-corrosive material, properly restrained and secured, on properly maintained public roads, with gross vehicle weights not in excess of factory rated capacity.

Sole and exclusive remedy:

If the product covered hereby fails to conform to the above stated warranty, Cargo Floor B.V. sole liability under this warranty and the owner's sole and exclusive remedy is limited to repair or replacement of the defective part(s) at a facility authorized by your dealer or Cargo Floor B.V.. This is the owner's sole and exclusive remedy for all contract claims, and all tort claims including those based on the strict liability in tort and negligence. Any defective part(s) must be shipped freight prepaid to your dealer who will contact Cargo Floor B.V..

Except as expressly set forth above, Cargo Floor B.V. makes no warranties:

Express, implied or statutory, specifically: No warranties of fitness for a particular purpose or warranties of merchantability are made. Further, Cargo Floor B.V. will not be liable for incidental damages or consequential damages such as, but not limited to, loss of use of the product, damage to the product, towing expenses, attorney's fees and the liability you may have in respect to any other reason.

Tort disclaimer:

Cargo Floor B.V. shall not have any liability in tort with respect to the products, including any liability based on strict liability in tort and negligence.

If this warranty violates law:

To the extent any provision of this warranty, contravenes the law of any jurisdiction, that provision shall be inapplicable in such jurisdiction and the remainder of the warranty shall not be affected thereby.

CONTACT DATA

Postal and visiting address:

Cargo Floor B.V.
Byte 14
7741 MK Coevorden
The Netherlands

Phone number : +31 524 593 900
E-mail : info@cargofloor.com
Website : www.cargofloor.com
Whatsapp : +31 524 593 900

Order spare parts:

E-mail address : sales2@cargofloor.com
Phone number : +31 524 593 944

After Sales (technical questions and malfunctions)

E-mail address : as@cargofloor.com
Phone number : +31 524 593 977
Whatsapp : +31 524 593 977

TER INFORMATIE
FOR INFORMATION
ZUR INFORMATION

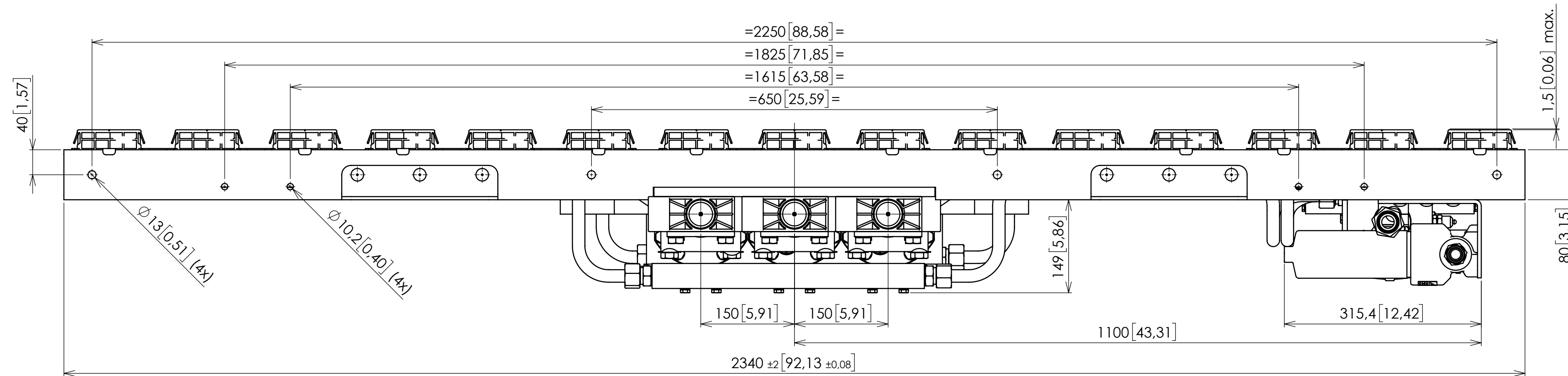
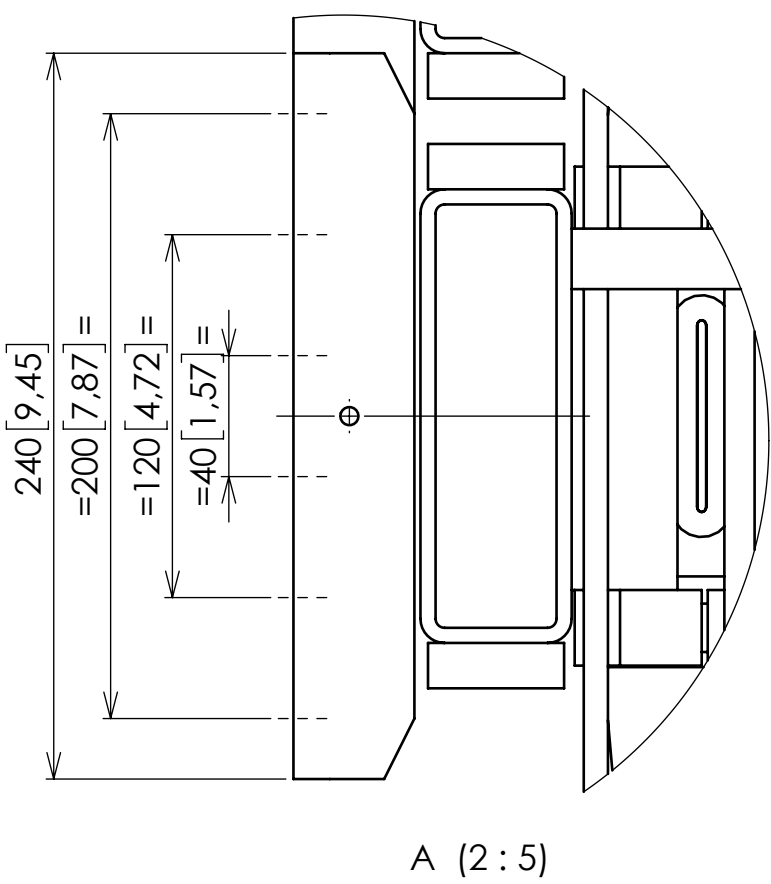
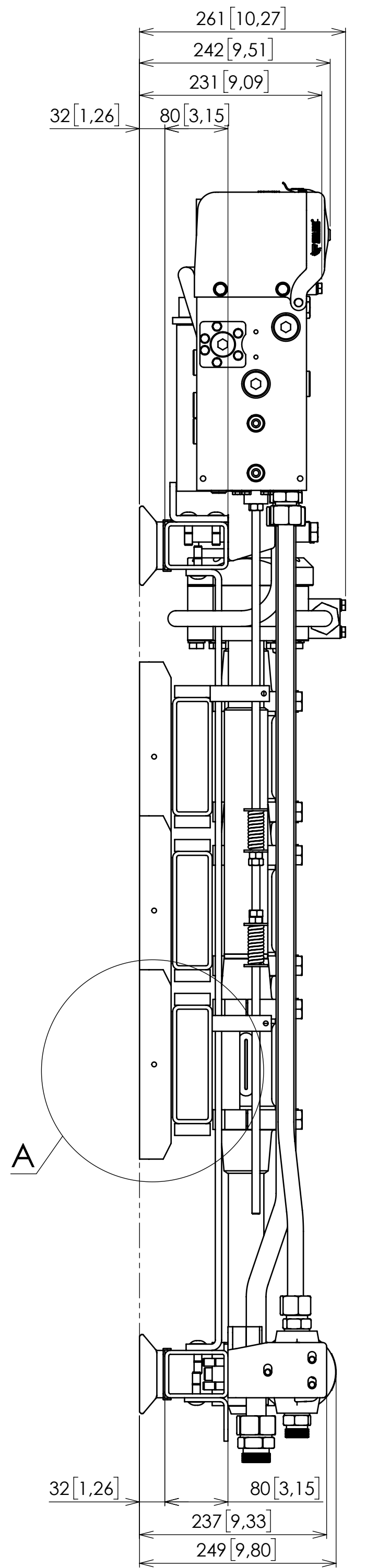
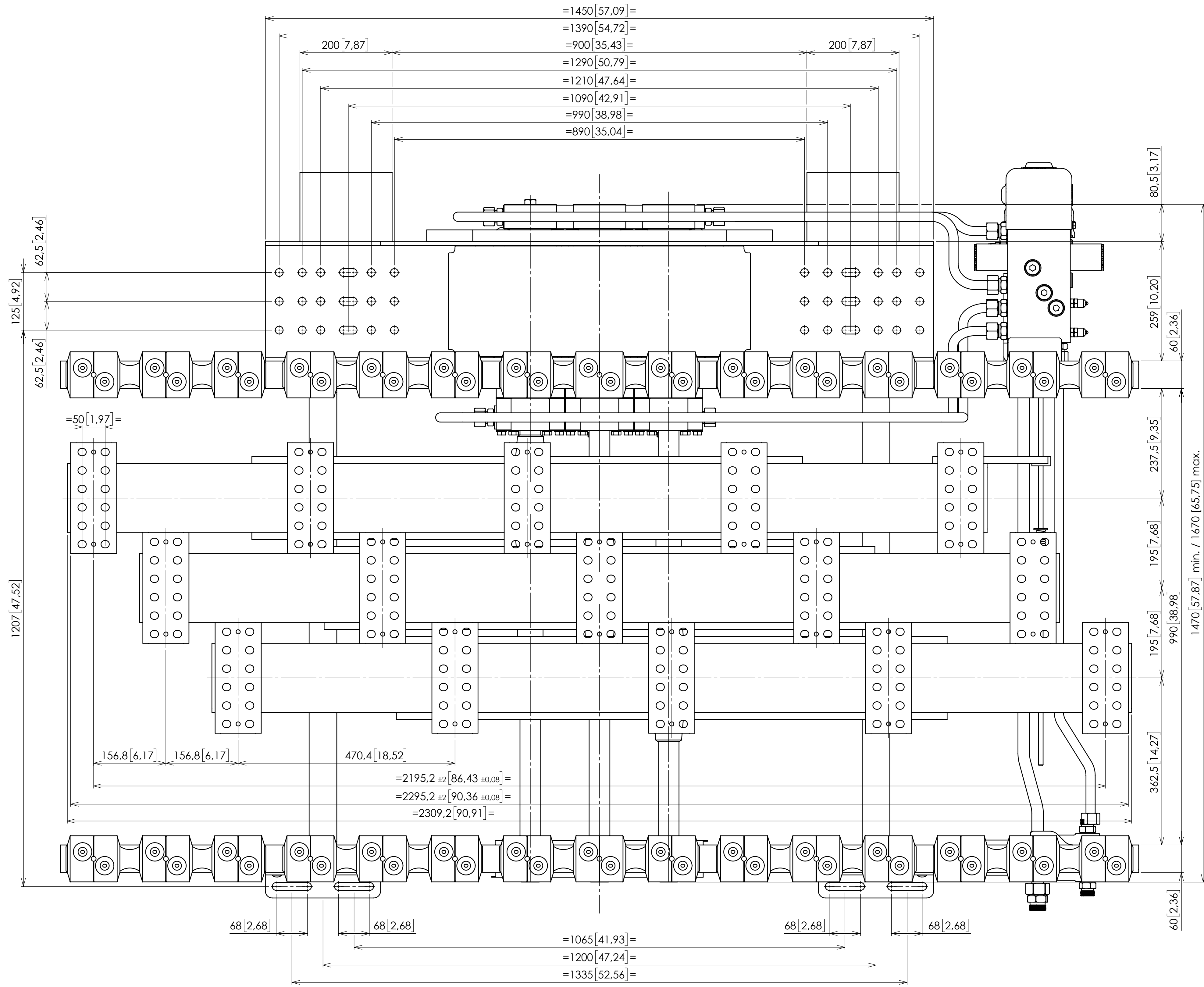
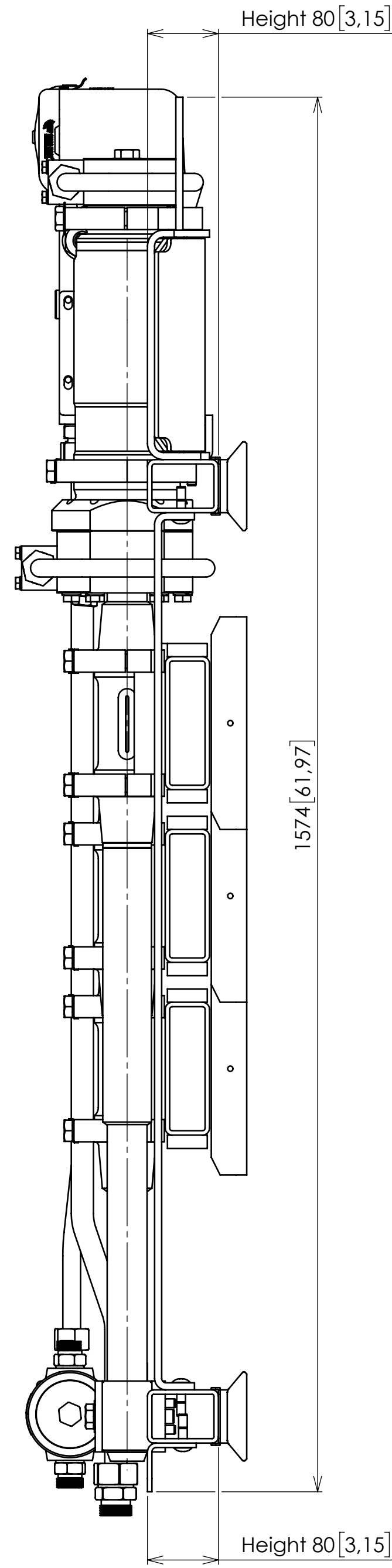

SUBJECT:
CF500 SL-C H80 15/156,8 E 12xM12

CARGO FLOOR
Cargo Floor B.V.
Stylé 14
NL-7741 MK Coevorden
Phone : +31-524-593900
Fax : +31-524-593909
E-mail : info@cargo-floor.com

REV.: 0 DATE: 19-12-18
DRAWN: GG-C DIMENSIONS IN MM

DRAWING NUMBER:
Page S1

THIS DRAWING IS THE PROPERTY OF CARGO FLOOR B.V. AND MUST NOT BE COPIED OR REPRODUCED WITHOUT THEIR WRITTEN AUTHORITY

TER INFORMATIE
FOR INFORMATION
ZUR INFORMATION

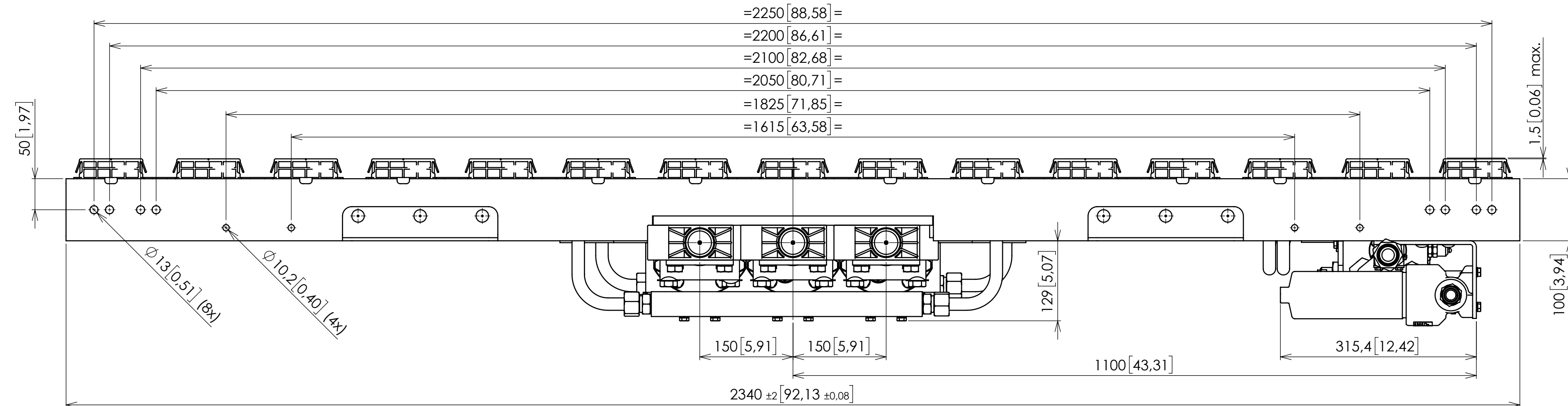
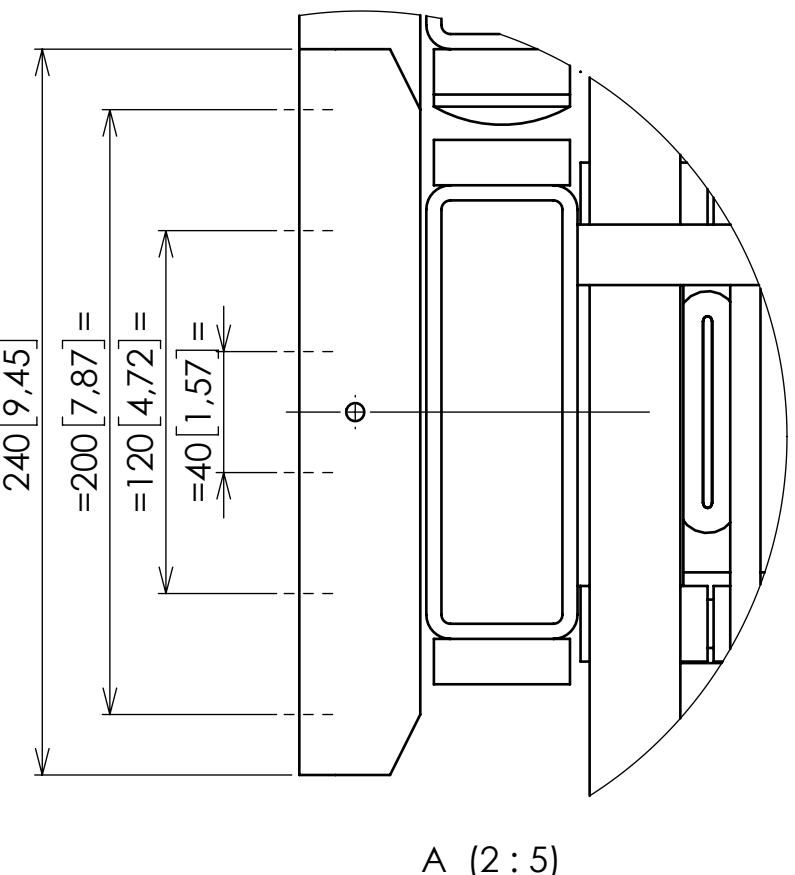
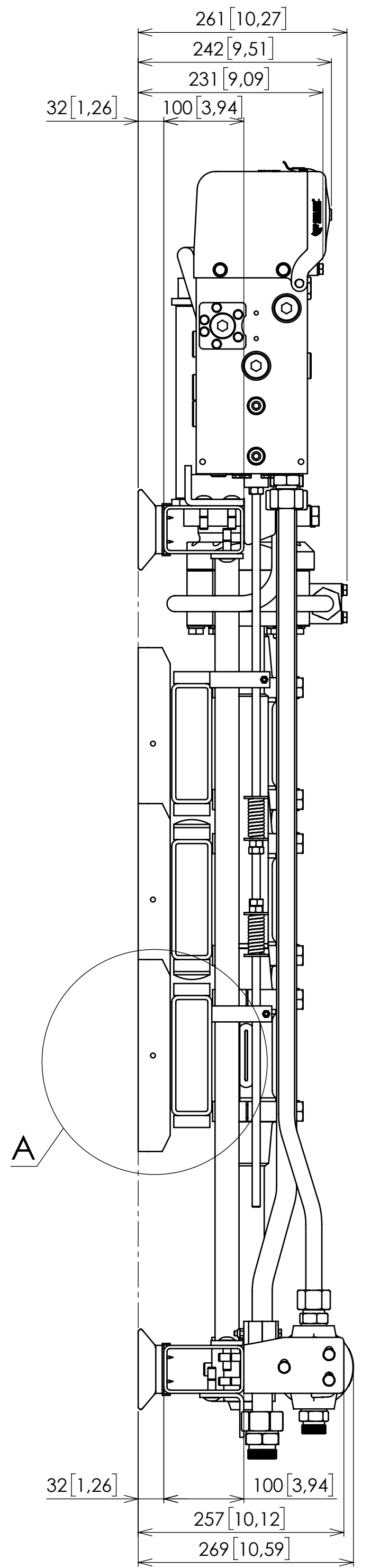
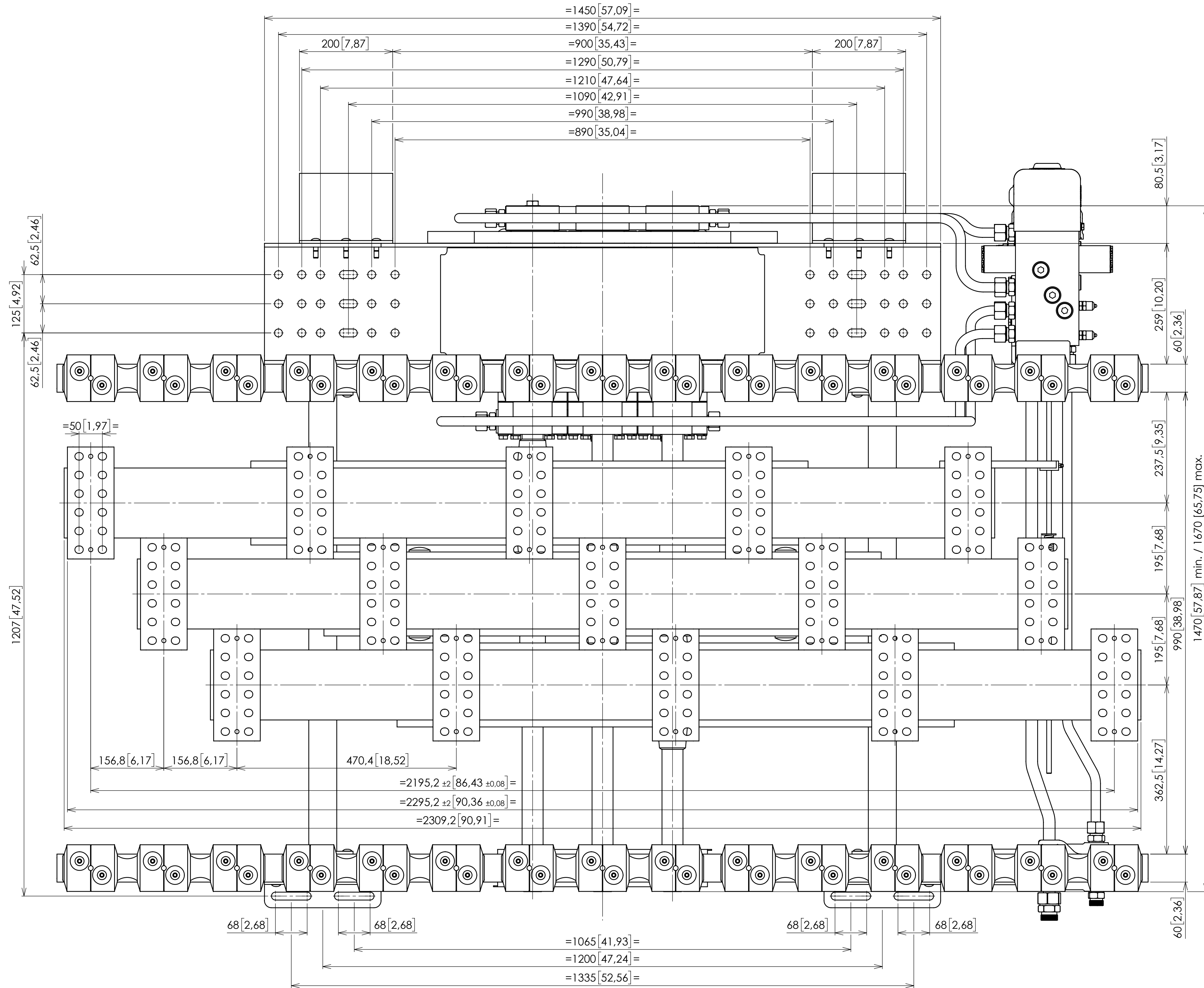
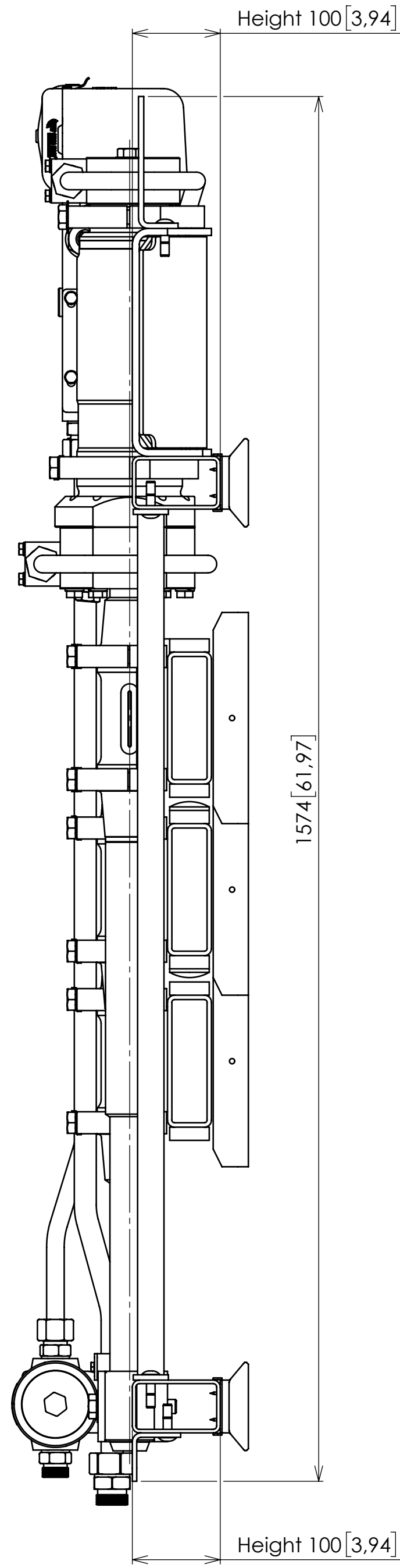

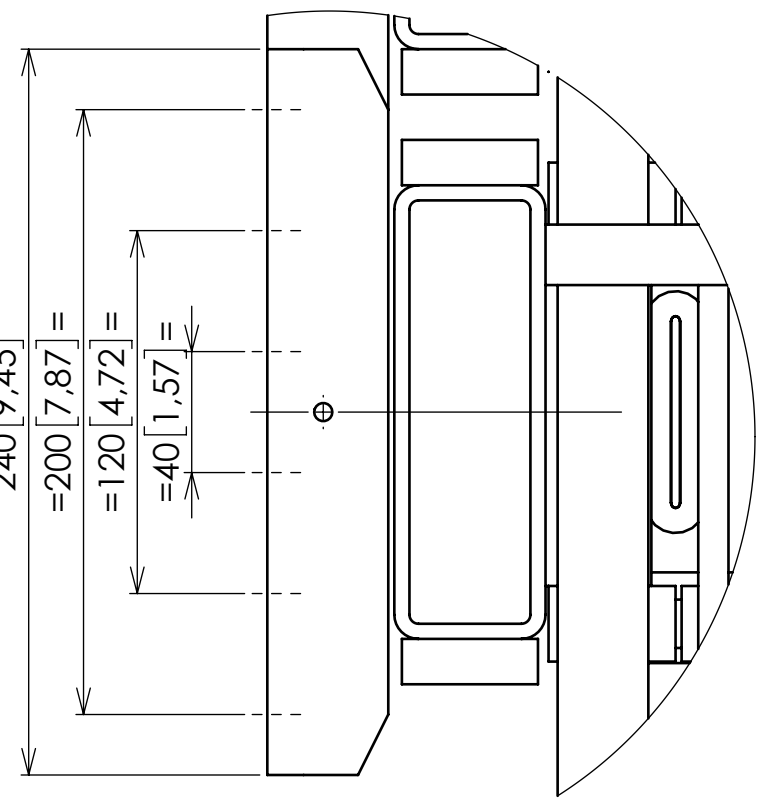
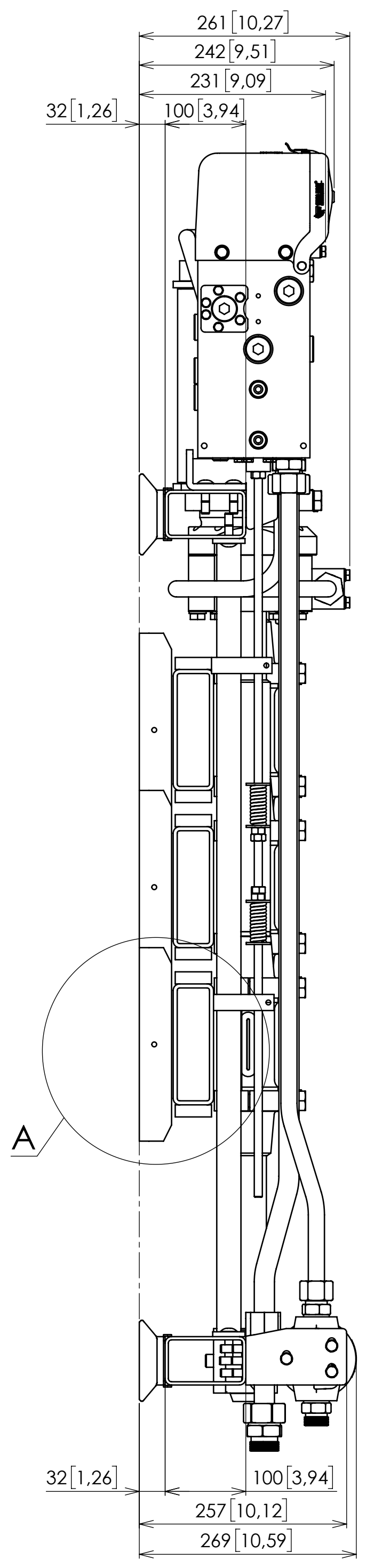
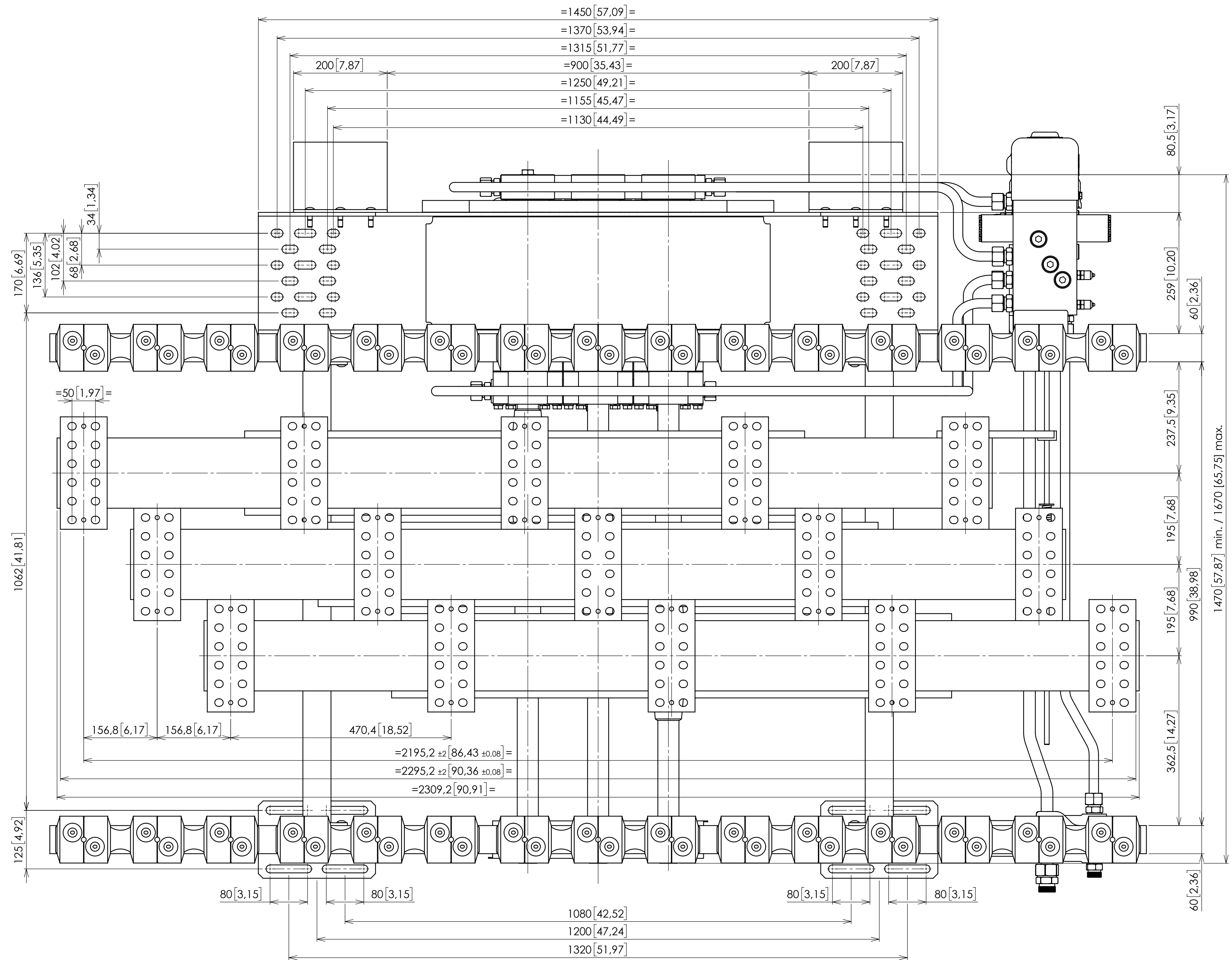
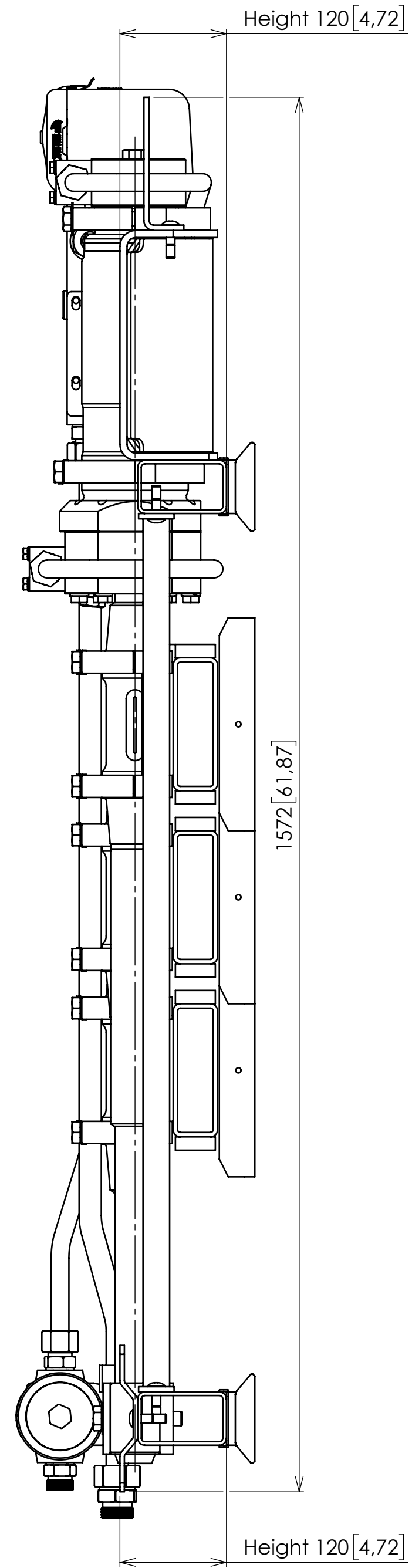

A (2:5)

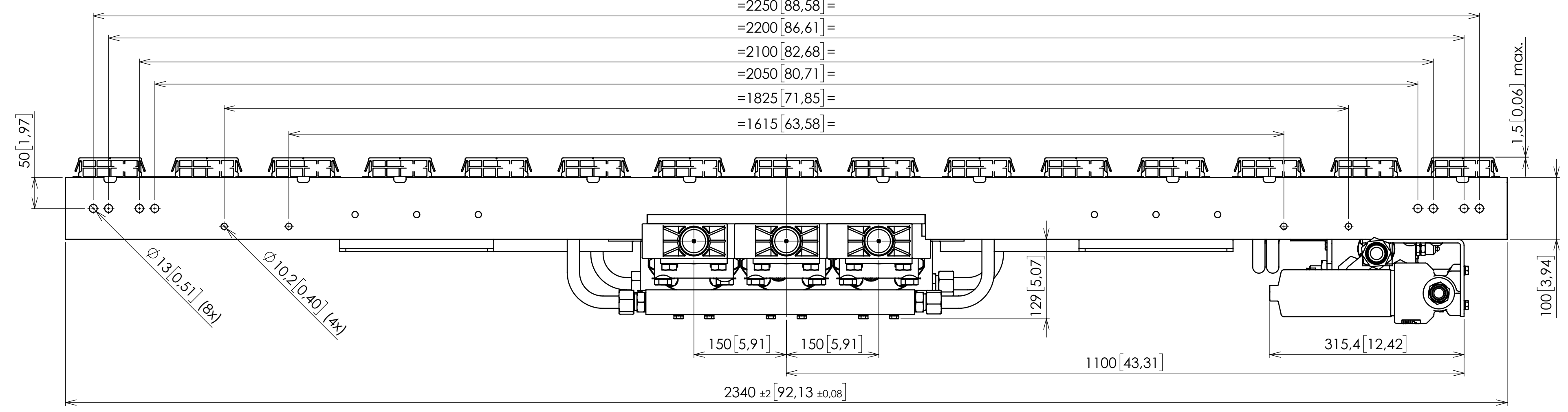

TER INFORMATIE
FOR INFORMATION
ZUR INFORMATION

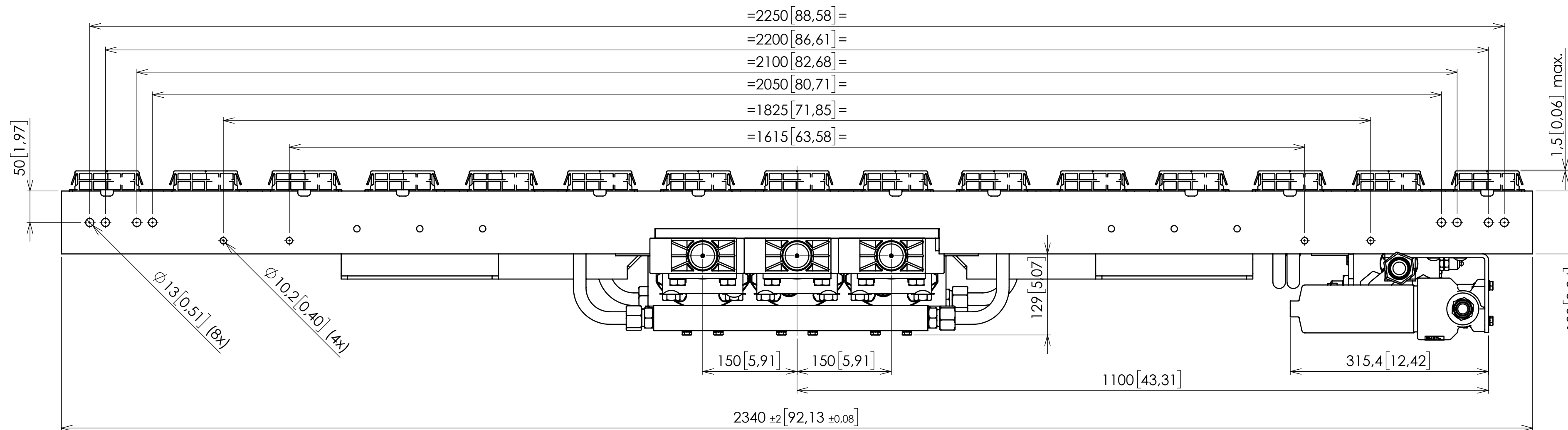
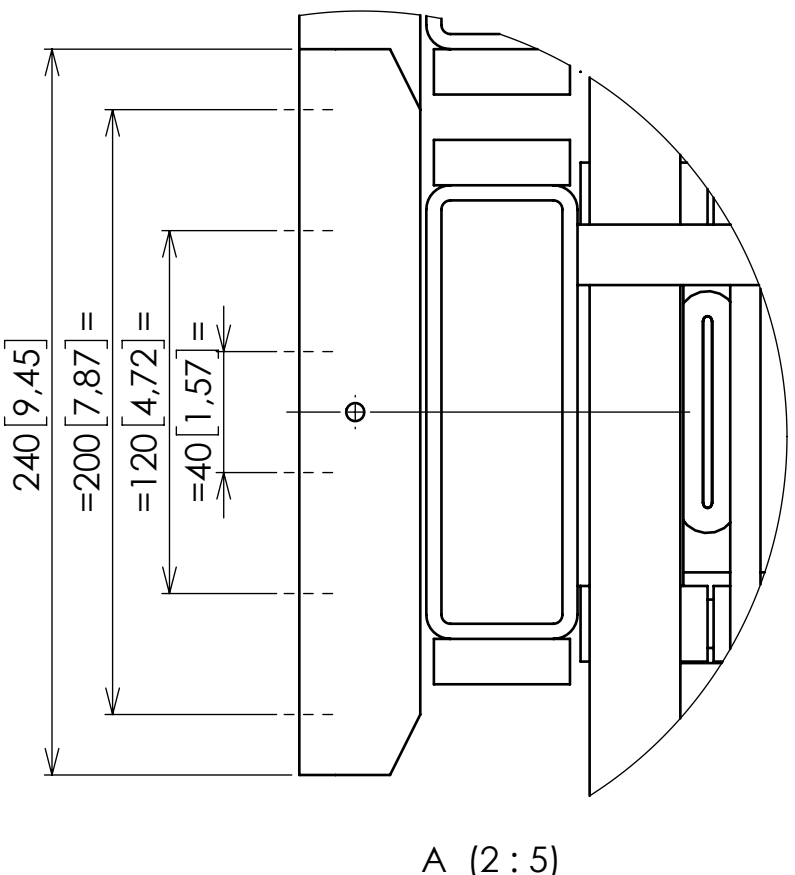
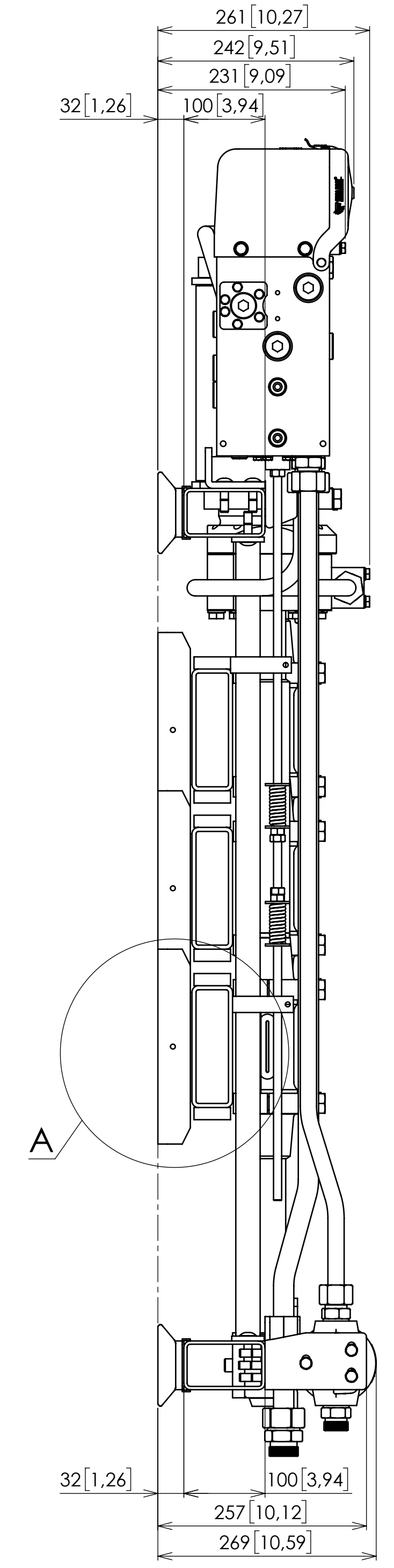
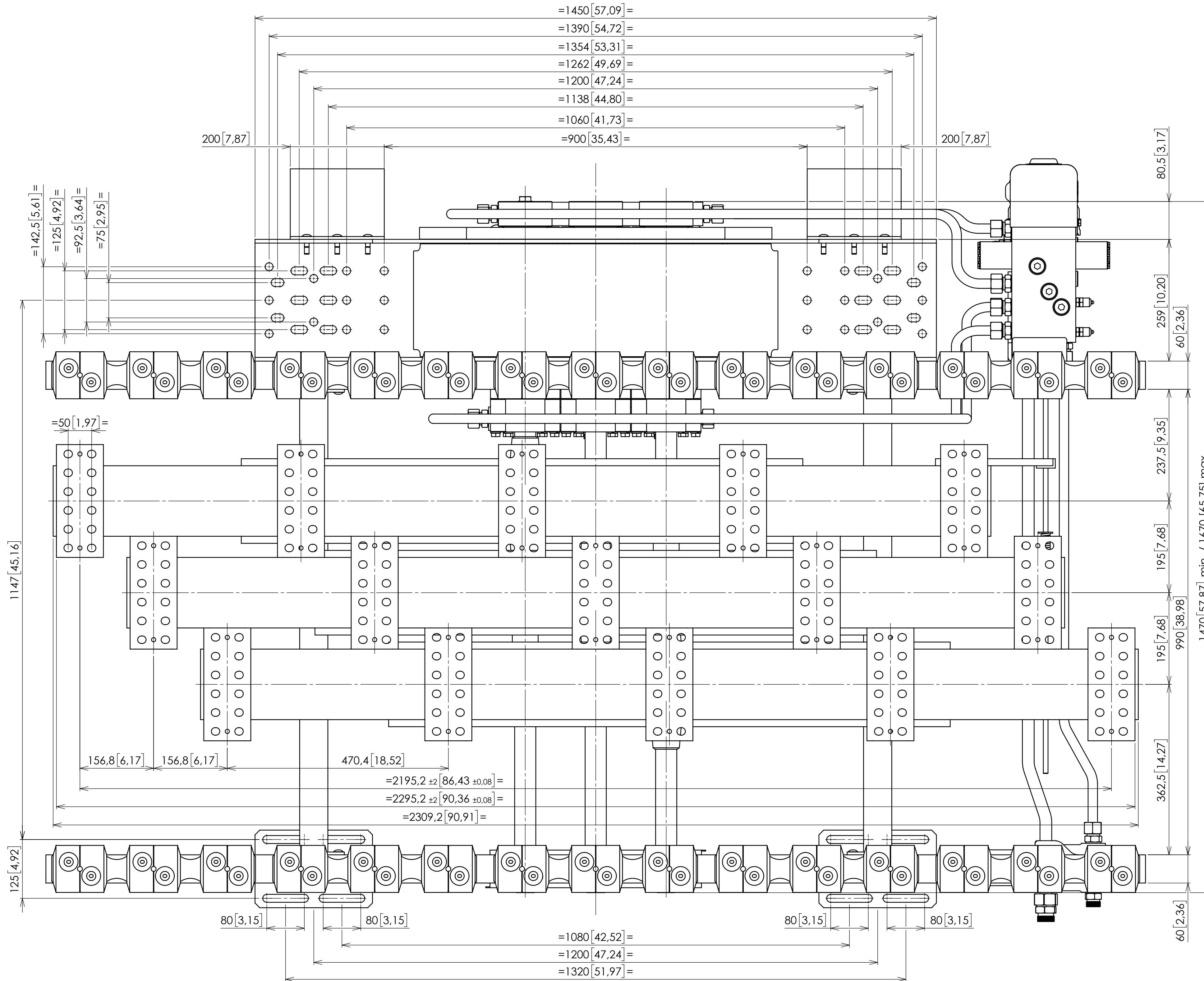
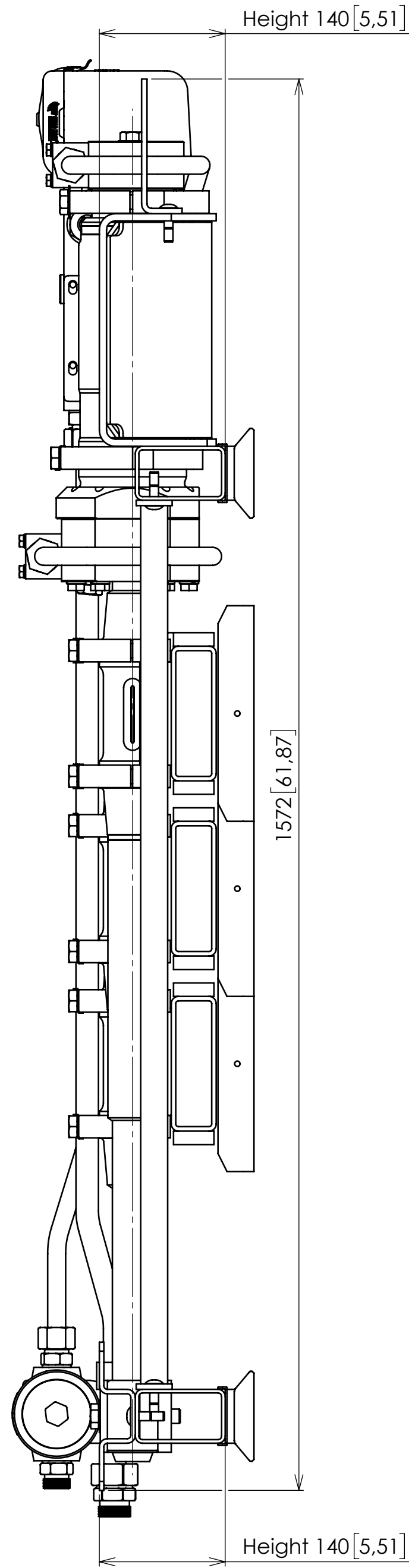

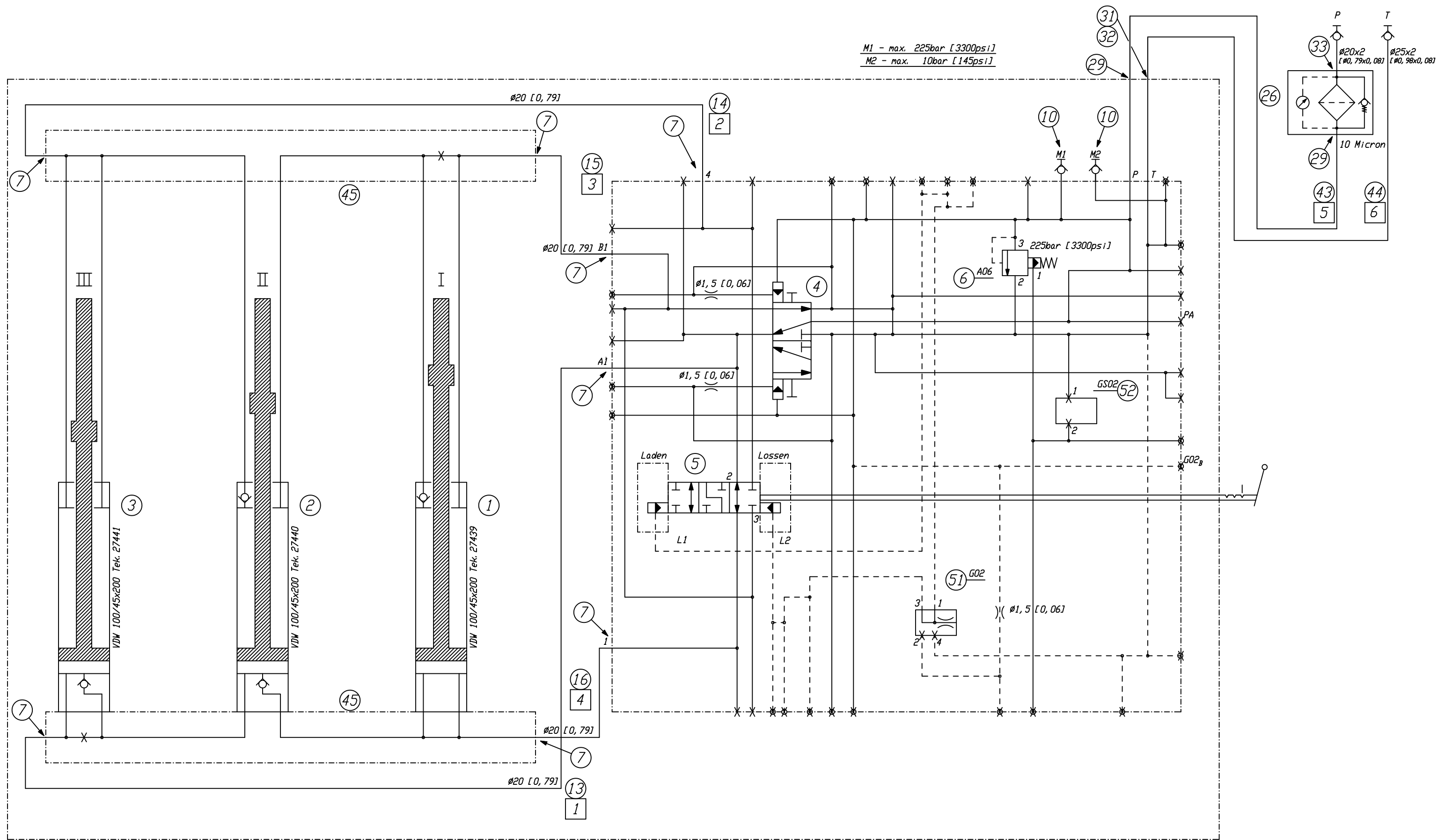

ACHTERZIJDE CHASSIS
 RUCKSEITE CHASSIS
 BACKSIDE FRAME
 DERRIERE DE CHASSIS

ONDERAANZICHT
 UNTERANSICHT
 BOTTOM VIEW
 VUE DESSOUS

METRIC [IMPERIAL]



CARGO FLOOR®
 Cargo Floor B.V.
 P.O. Box 271
 NL-7740 AG Coevorden
 Phone: +31-524-593900
 Fax: +31-524-593999
 E-mail: info@cargofloor.com



PROJECT:
CF500 SL-C
 SUBJECT:
A-bediening / A-Control / A-Bedienung
 All rights strictly reserved. Reproductions or issue to third parties in any form whatever is not permitted without written authority from the proprietor.

ORDER: ...
 DATE: 12-09-12
 DRAWN: H.Z.

REV	DATE	CHANGES	MP	BY
A	10-06-13	Metric+Imperial	MP	

PAGE
H1-A
 DRAWING NUMBER :
Inbouwboek

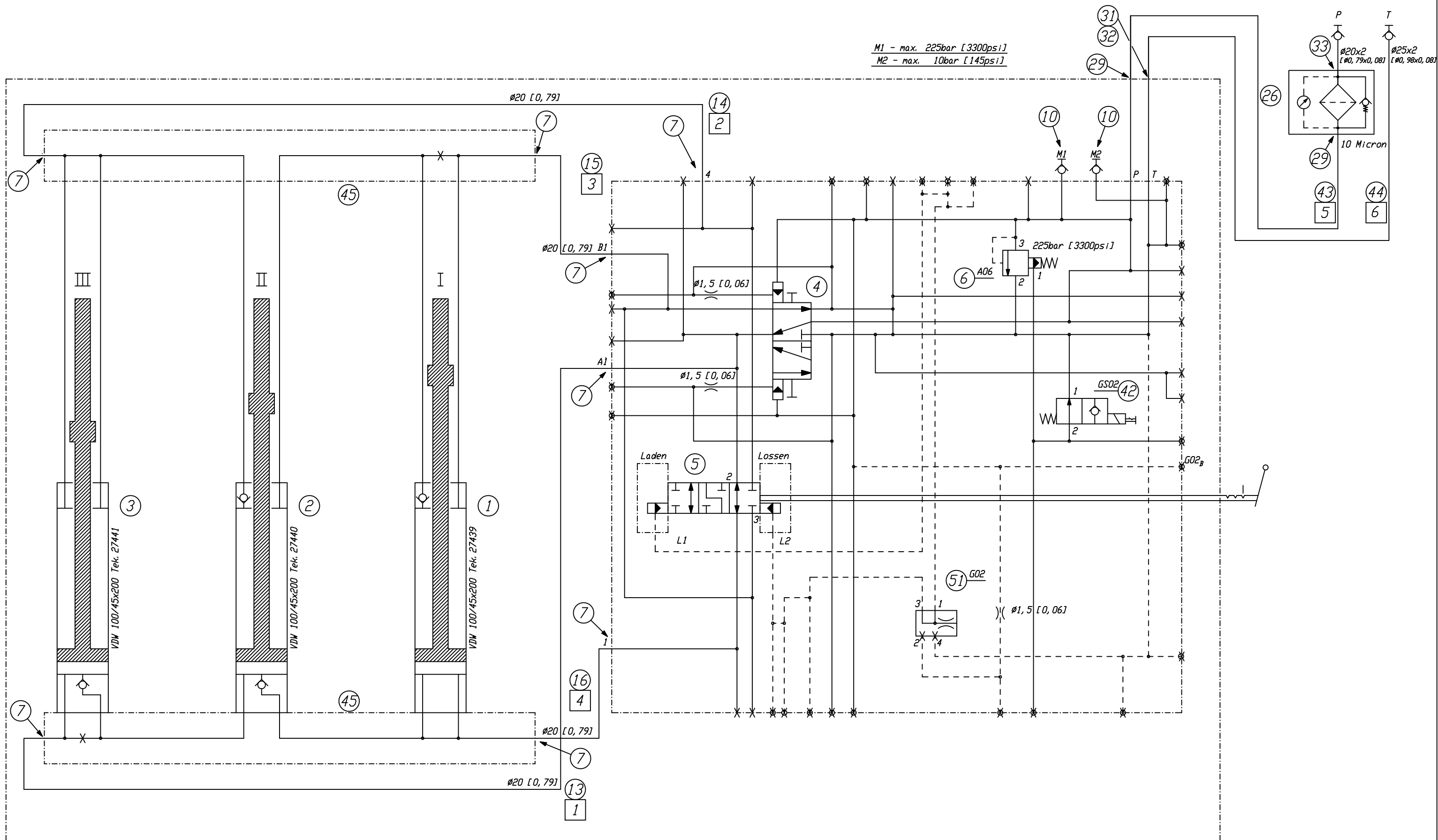

M1 - max. 225bar [3300psi]
M2 - max. 10bar [145psi]

ACHTERZIJDE CHASSIS
RUCKSEITE CHASSIS
BACKSIDE FRAME
DERRIERE DE CHASSIS

ONDERAANZICHT
UNTERANSICHT
BOTTOM VIEW
VUE DESSOUS

METRIC [IMPERIAL]



Cargo Floor B.V.
P.O. Box 271
NL-7740 AG Coevorden
Phone: +31-524-593900
Fax: +31-524-593999
E-mail: info@cargo-floor.com



PROJECT:
CF500 SL-C
SUBJECT:
B-bediening / B-Control / B-Bedienung

All rights strictly reserved. Reproductions or issue to third parties in any form whatever is not permitted without written authority from the proprietor.

ORDER: ...

DATE: 12-09-12

DRAWN: H.Z.

PAGE

H1-B

DRAWING NUMBER :

Inbouwboek

A 10-06-13 Metric+Imperial
REV DATE CHANGES

MP
BY

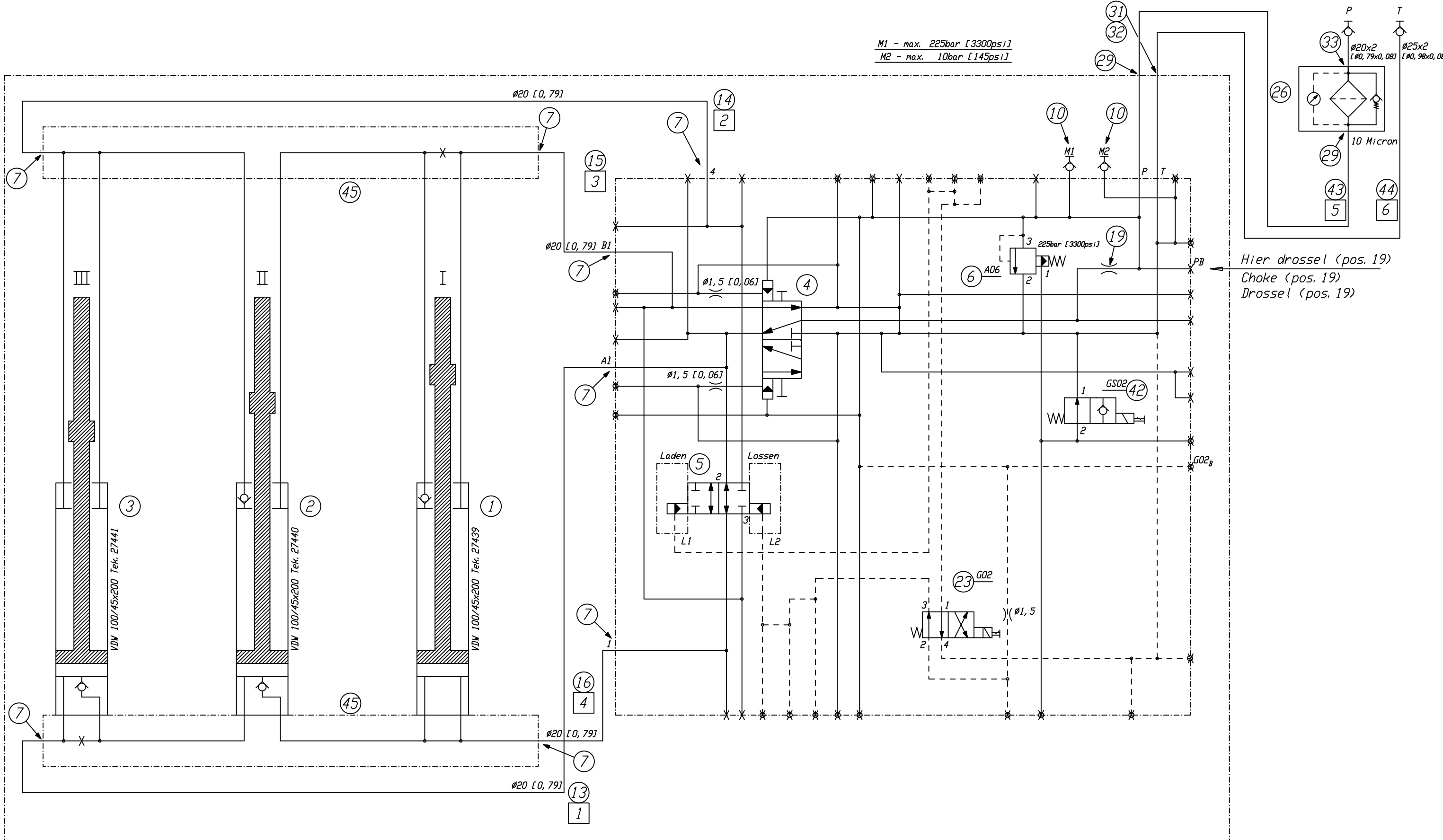

Hier drossel (pos. 19)
Choke (pos. 19)
Drossel (pos. 19)

ACHTERZIJDE CHASSIS
RUCKSEITE CHASSIS
BACKSIDE FRAME
DERRIERE DE CHASSIS

ONDERAANZICHT
UNTERANSICHT
BOTTOM VIEW
VUE DESSOUS

METRIC [IMPERIAL]

CARGO FLOOR®

Cargo Floor B.V.
P.O. Box 271
NL-7740 AG Coevorden
Phone: +31-524-593900
Fax: +31-524-593999
E-mail: info@cargo-floor.com



PROJECT:
CF500 SL-C

SUBJECT:
E-bediening / E-Control / E-Bedienung

All rights strictly reserved. Reproductions or issue to third parties in any form whatever is not permitted without written authority from the proprietor.

ORDER: ...
DATE: 12-09-12
DRAWN: H.Z.

REV	DATE	CHANGES	MP	BY
A	10-06-13	Metric+Imperial	MP	

PAGE
H1-E

DRAWING NUMBER :
Inbouwboek

CF500 SL-C

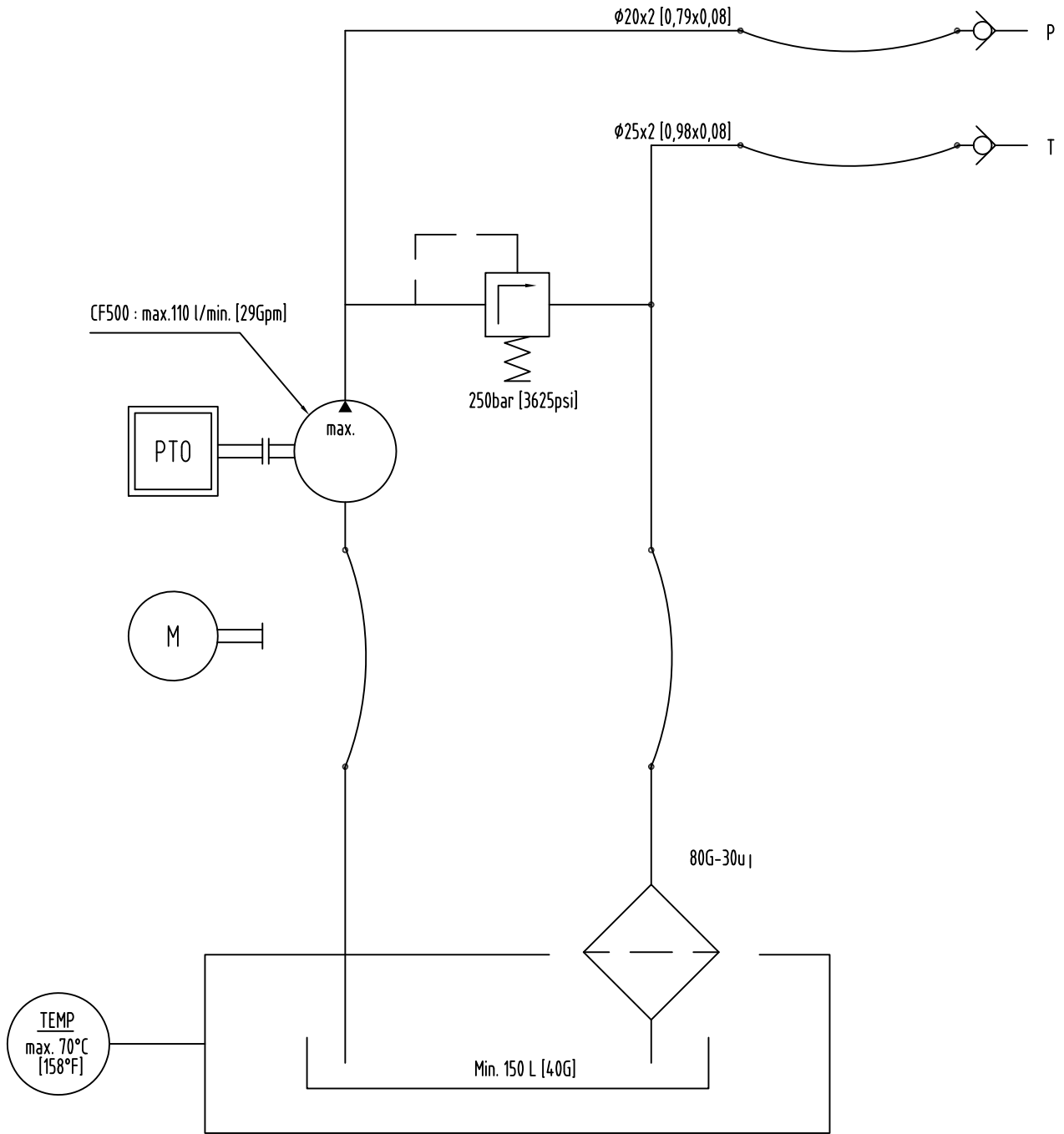

SUBJECT: Aansluiting / Connection / Anschlüsse	REV.: A	DATE: 05-10-12
	DRAWN: HZ	DIMENSIONS IN MM
	<small> Cargo Floor B.V. P.O. Box 271 NL-7740 AG Coevorden Phone: +31-524-593900 Fax: +31-524-593999 Internet: www.cargofloor.com E-mail: info@cargofloor.com </small>	
DRAWING NUMBER: <h2 style="text-align: center;">Page H2</h2>		
<small>This drawing is the property of Cargo Floor B.V. and must not be copied or reproduced without their written authority</small>		

OPTION IRCM REMOTE CONTROL

Art.no. 6104047

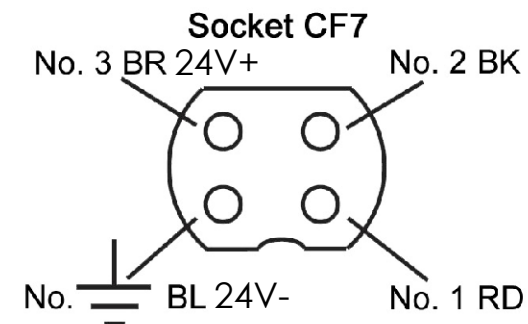
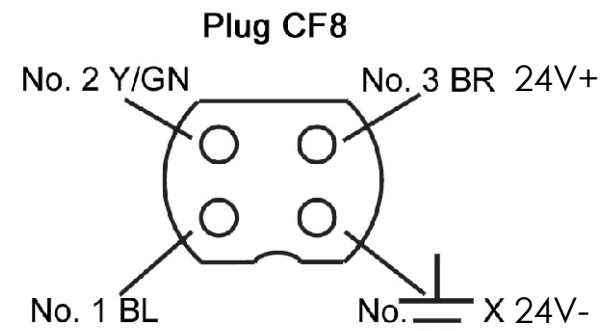
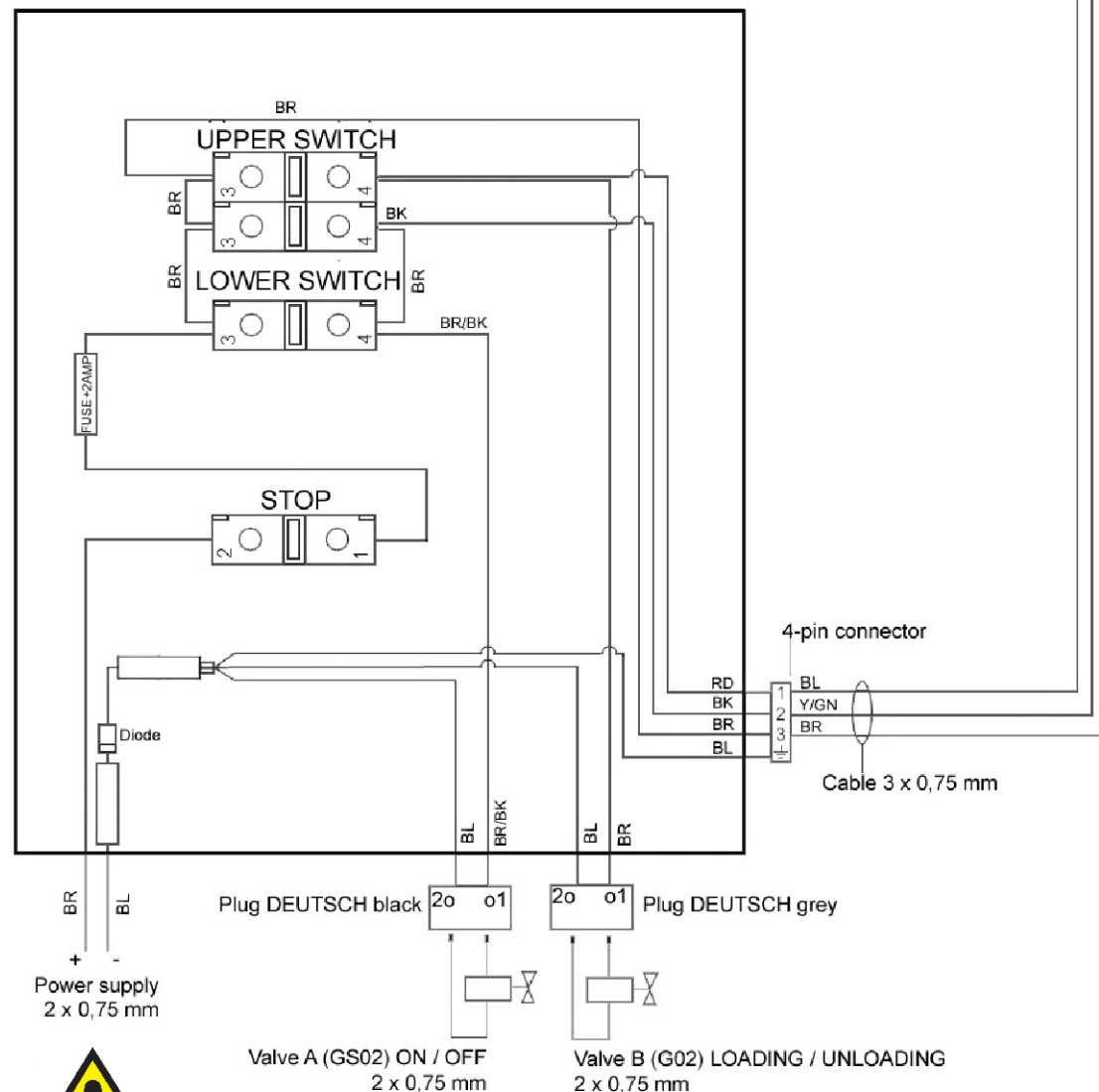
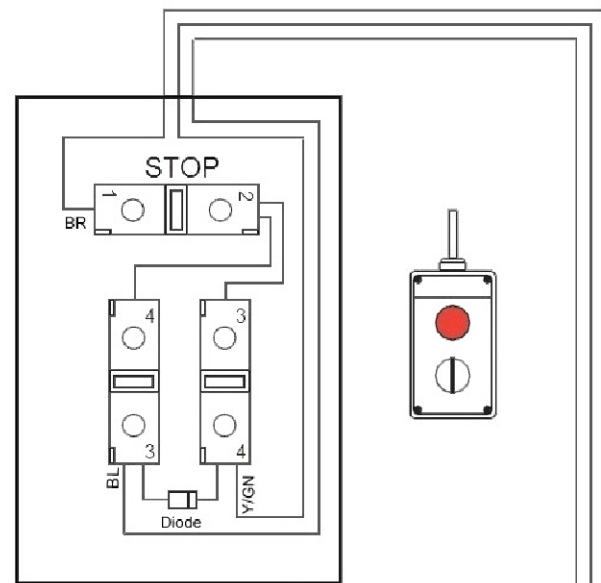
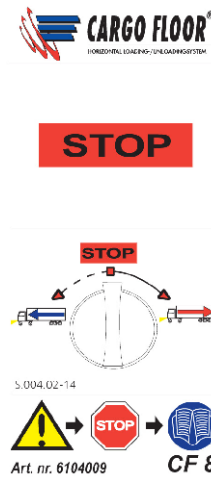

4-pin connector

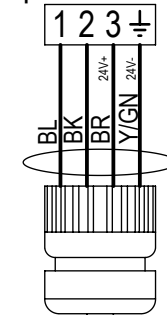

cable 4 x 0,75 mm²

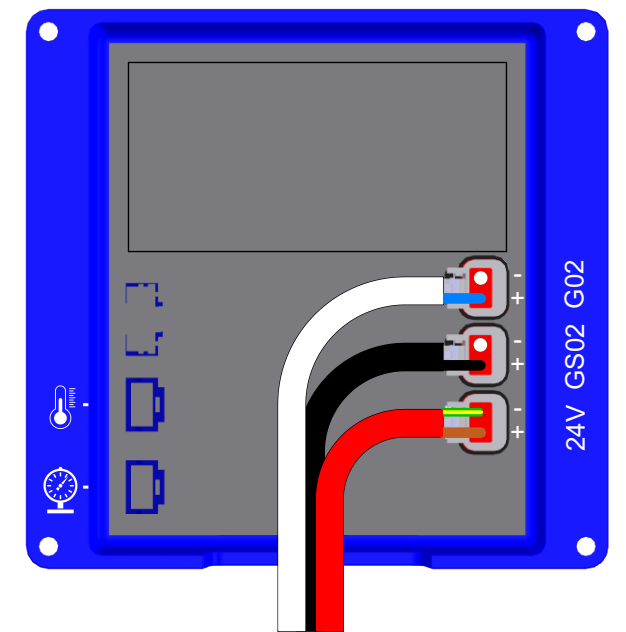

D	GG-C	24-06-2021	Updated; changed radio control set and receiver
E	GG-C	13-01-2023	Replaced radio control set (6104006) with IRCM (6104047), and CF-RX box with receiver (6104048)
REV.	BY	DATE	DESCRIPTION

TOLERANCES UNLESS OTHERWISE STATED:		SIZE: A3	STATUS: Released	ART. NO.: -
PROJECT: CF500 + all other types				DIMENSIONS: MM [INCH]
DESCRIPTION: Electric drawing E				MATERIAL: -
DRAWN:		SCALE: 1:1	SHEET: 1/1	DR. DATE: 8-3-2017
APR. BY:		APR. DATE:		
TREATMENT:				
CATEGORY:				
DRAWING NUMBER:				Page E1
DEBURR SHARP EDGES		WEIGHT: 0.00 KG		

OPTION IRCM REMOTE CONTROL

Art.no. 6104047

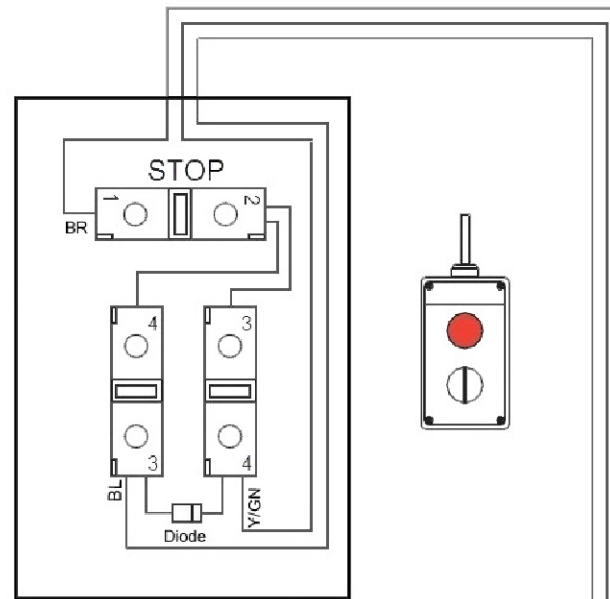
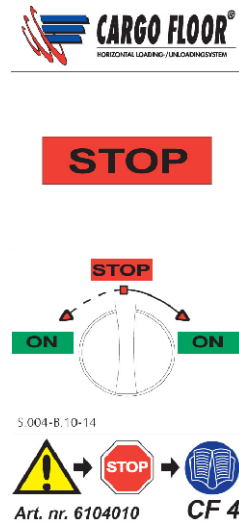

4-pin connector

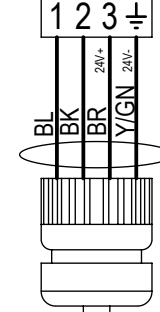

cable 4 x 0,75 mm²

Plug CF8

No. 2 Y/GN No. 3 BR 24V+

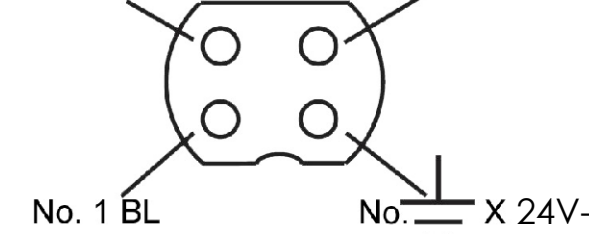

Socket CF7

No. 3 BR 24V+ No. 2 BK
No. 1 BL 24V- No. 1 RD

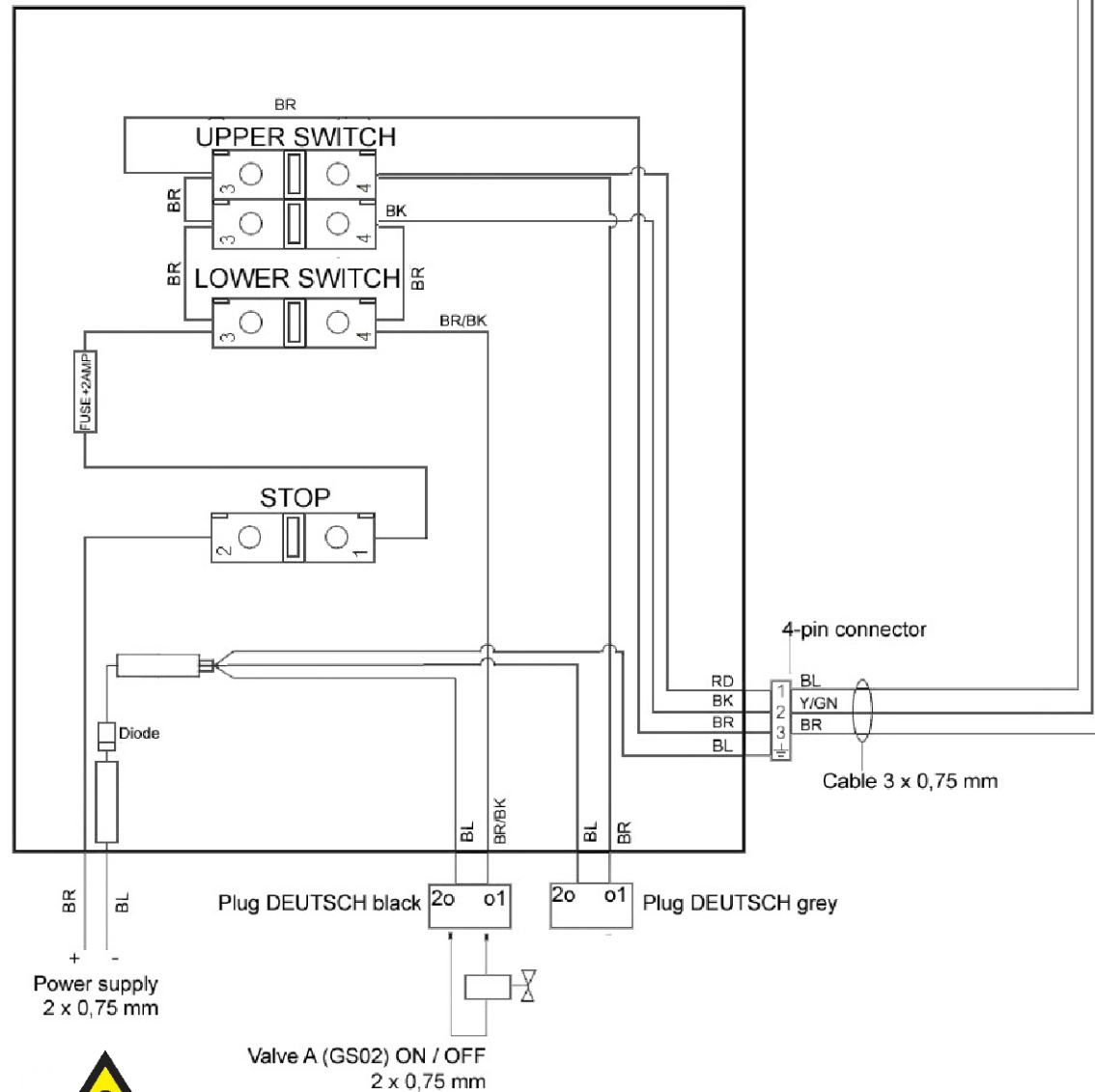
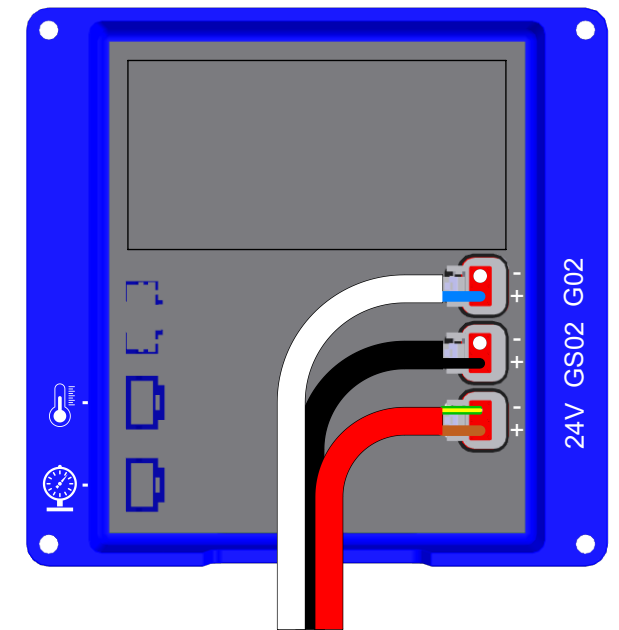

C	GG-C	24-06-2021	Updated; changed radio control set and receiver
D	GG-C	13-01-2023	Replaced radio control set (6104006) with IRCM (6104047), and CF-RX box with receiver (6104048)
REV.	BY	DATE	DESCRIPTION
TOLERANCES UNLESS OTHERWISE STATED:			
			SIZE: A3 STATUS: Released
			ART. NO.: -
			DIMENSIONS: MM [INCH]
			MATERIAL: -
			SCALE: 1:1 SHEET: 1/1
			DRAWN: DR. DATE: 8-3-2017
			APR. BY: APR. DATE:
			TREATMENT:
			CATEGORY:
			DRAWING NUMBER:
			Page E2
			DEBURR SHARP EDGES WEIGHT: 0.00 KG



Byte 14
NL-7741 MK Coevorden
Phone : +31-524-593900
E-mail : info@cargofloor.com

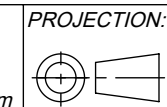

PROJECTION: **Released**

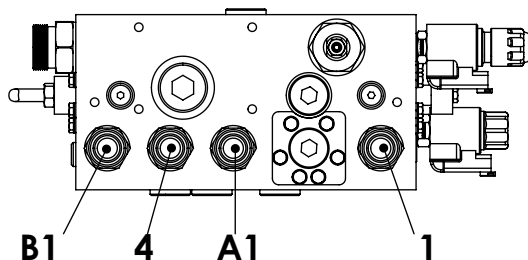
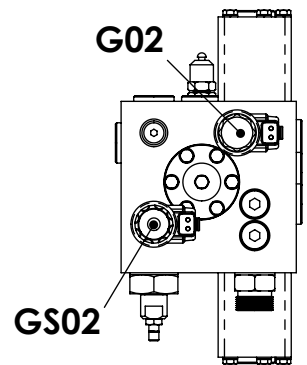
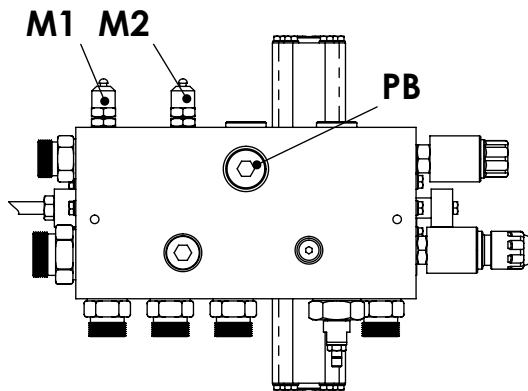
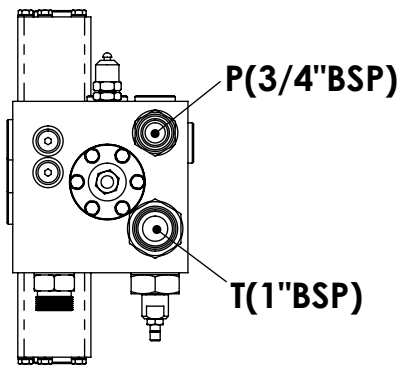
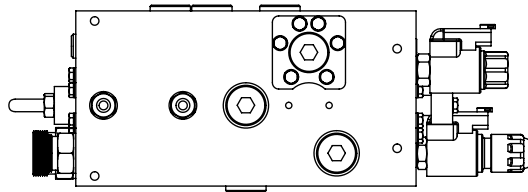
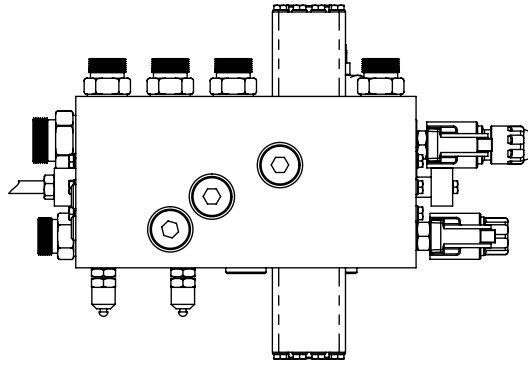

SUBJECT:

Control valve 02 "E" operation

REV.: B DIMENSIONS IN MM

DRAWN: H.Z. DATE: 12-09-12

DRAWING NUMBER:



Cargo Floor B.V.
 Byte 14
 NL-7741 MK Coevorden
 Phone : +31-524-593900
 Fax : +31-524-593999
 E-mail : info@cargofloor.com



Page BV1

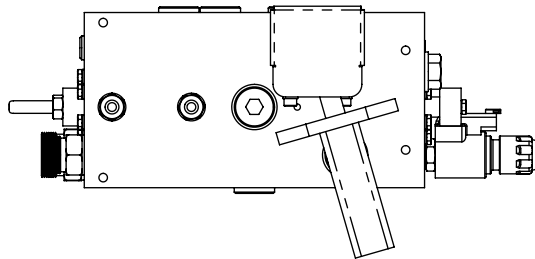
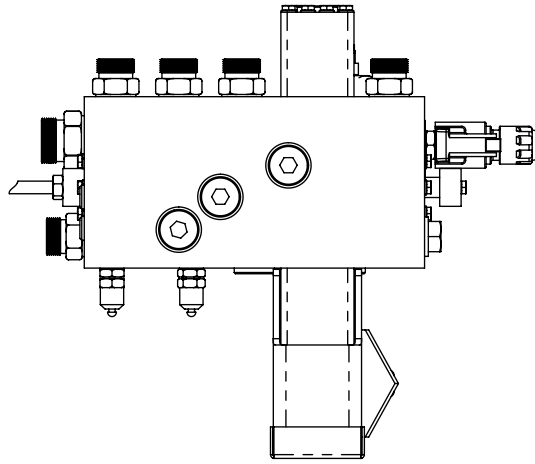

2	<i>Laden, load, Beladen, Charger</i>
0	<i>Stop, Stop Halt, Arrêt</i>
1	<i>Lossen, Unload, Entladen, Décharger</i>

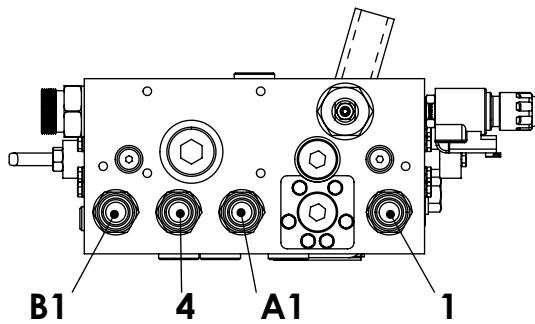
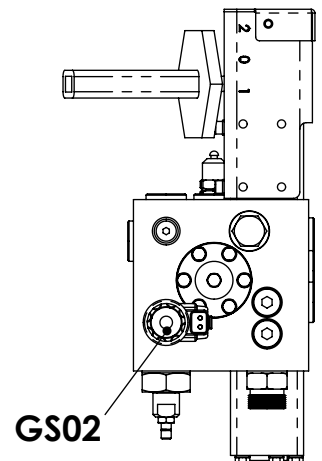
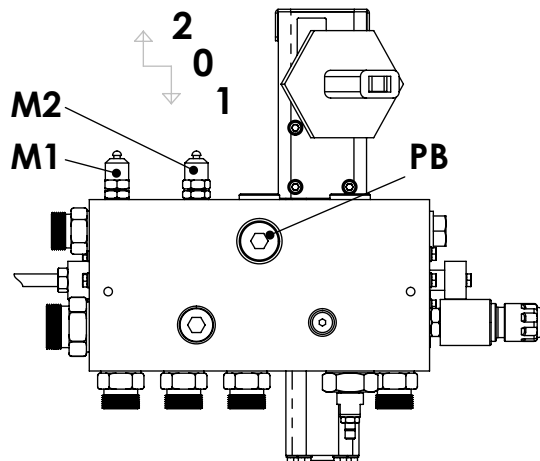
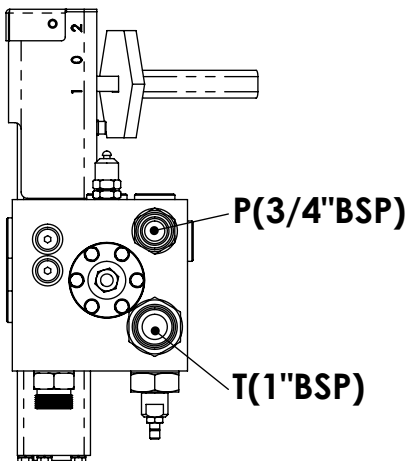

SUBJECT:

Control valve 02 "B" operation

REVISION: E DIMENSIONS IN MM

DRAWN: H.Z. DATE: 12-09-12



Cargo Floor B.V.
 Byte 14
 NL-7741 MK Coevorden
 Phone : +31-524-593900
 Fax : +31-524-593999
 E-mail : info@cargofloor.com



DRAWING NUMBER:

Page BV2